

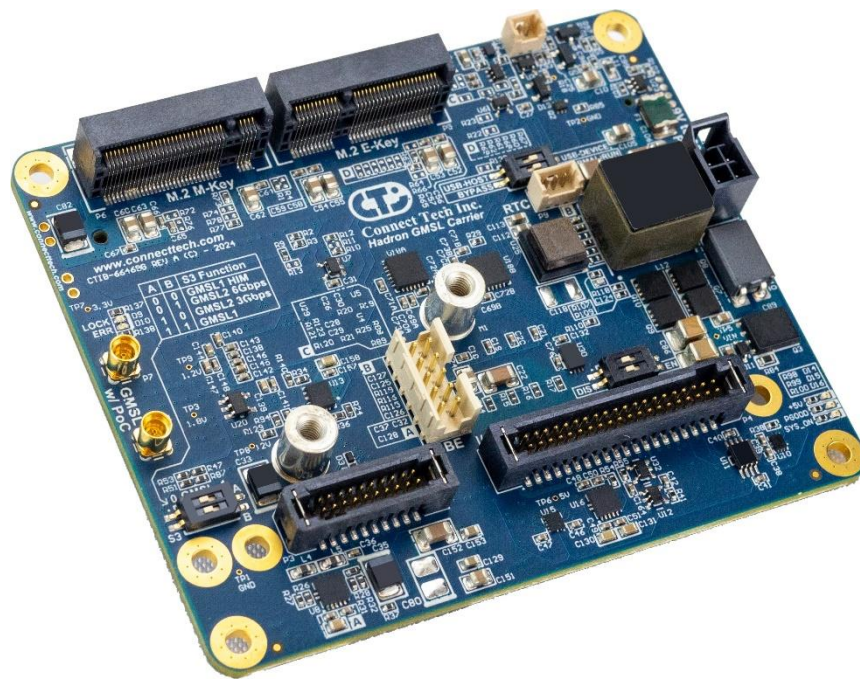

Connect Tech Inc.
Embedded Computing Experts

USERS GUIDE



Hadron GMSL Carrier

CTIM-00097(0.03) 2024-12-23



CONNECT TECH

www.connecttech.com

sales@connecttech.com

TABLE OF CONTENTS

Table of Contents	2
Preface	4
Disclaimer	4
Customer Support Overview.....	4
Contact Information	4
Limited Product Warranty	5
Copyright Notice.....	5
Trademark Acknowledgment.....	5
ESD Warning	6
Revision History	6
Introduction	7
Product Feature and Specifications.....	7
Part Numbers / Ordering Information.....	8
Product Overview	8
Block Diagram	8
Connector Locations	9
Connector Summary	10
Switch Summary	10
Detailed Feature Description.....	11
Jetson Orin™ NX / Orin™ Nano Module Connector.....	11
10/100/1000 Ethernet Connectors.....	12
USB 3.1 Connector	13
I/O Header.....	14
M.2 E-Key – WiFi and Bluetooth Expansion Port	16
M.2 M-Key – NVMe	16
GMSL Coax Connectors.....	17
Power Header.....	18
3-Pin RTC Battery Connector.....	19
+5V Fan Connector.....	19
Force Recovery / Reset Connector	20

USB Host / Device Mode and Power Switch	21
CAN BUS Termination Resistor	21
GMSL Mode Select	22
GMSL Mode Select S3 Combinations.....	22
LED Power Indicators.....	23
LED GMSL Status Indicators.....	23
Typical Installation	24
MECHANICAL Details	25
Thermal Details.....	29
Cable Information.....	30
Cable Components:.....	30
Connect Tech Custom Thermal Solutions	31
POWER Consumption Details	32
Software / BSP Details.....	32

PREFACE

Disclaimer

The information contained within this user's guide, including but not limited to any product specification, is subject to change without notice.

Connect Tech assumes no liability for any damages incurred directly or indirectly from any technical or typographical errors or omissions contained herein or for discrepancies between the product and the user's guide.

Customer Support Overview

If you experience difficulties after reading the manual and/or using the product, contact the Connect Tech reseller from which you purchased the product. In most cases the reseller can help you with product installation and difficulties.

In the event that the reseller is unable to resolve your problem, our highly qualified support staff can assist you. Our support section is available 24 hours a day, 7 days a week on our website at:

<https://connecttech.com/support/resource-center/>. See the contact information section below for more information on how to contact us directly. Our technical support is always free.

Contact Information

Contact Information	
Mail/Courier	Connect Tech Inc. Technical Support 489 Clair Road West Guelph, Ontario Canada N1L 0H7
Contact Information	sales@connecttech.com support@connecttech.com www.connecttech.com Toll Free: 800-426-8979 (North America only) Telephone: +1-519-836-1291 Facsimile: 519-836-4878 (on-line 24 hours)
Support	Please go to the Connect Tech Resource Center for product manuals, installation guides, device drivers, BSPs and technical tips. Submit your technical support questions to our support engineers. Technical Support representatives are available Monday through Friday, from 8:30 a.m. to 5:00 p.m. Eastern Standard Time.

Limited Product Warranty

Connect Tech Inc. provides a one-year Warranty for this product. Should this product, in Connect Tech Inc.'s opinion, fail to be in good working order during the warranty period, Connect Tech Inc. will, at its option, repair or replace this product at no charge, provided that the product has not been subjected to abuse, misuse, accident, disaster or non-Connect Tech Inc. authorized modification or repair.

You may obtain warranty service by delivering this product to an authorized Connect Tech Inc. business partner or to Connect Tech Inc. along with proof of purchase. Product returned to Connect Tech Inc. must be pre-authorized by Connect Tech Inc. with an RMA (Return Material Authorization) number marked on the outside of the package and sent prepaid, insured and packaged for safe shipment. Connect Tech Inc. will return this product by prepaid ground shipment service.

The Connect Tech Inc. Limited Warranty is only valid over the serviceable life of the product. This is defined as the period during which all components are available. Should the product prove to be irreparable, Connect Tech Inc. reserves the right to substitute an equivalent product if available or to retract the Warranty if no replacement is available.

The above warranty is the only warranty authorized by Connect Tech Inc. Under no circumstances will Connect Tech Inc. be liable in any way for any damages, including any lost profits, lost savings or other incidental or consequential damages arising out of the use of, or inability to use, such product.

Copyright Notice

The information contained in this document is subject to change without notice. Connect Tech Inc. shall not be liable for errors contained herein or for incidental consequential damages in connection with the furnishing, performance, or use of this material. This document contains proprietary information that is protected by copyright. All rights are reserved. No part of this document may be photocopied, reproduced, or translated to another language without the prior written consent of Connect Tech, Inc.

Copyright © 2024 by Connect Tech, Inc.

Trademark Acknowledgment

Connect Tech, Inc. acknowledges all trademarks, registered trademarks and/or copyrights referred to in this document as the property of their respective owners. Not listing all possible trademarks or copyright acknowledgments does not constitute a lack of acknowledgment to the rightful owners of the trademarks and copyrights mentioned in this document.

ESD Warning



Electronic components and circuits are sensitive to Electrostatic Discharge (ESD). When handling any circuit board assemblies including Connect Tech COM Express carrier assemblies, it is recommended that ESD safety precautions be observed. ESD safe best practices include, but are not limited to:

- Leaving circuit boards in their antistatic packaging until they are ready to be installed.
- Using a grounded wrist strap when handling circuit boards, at a minimum you should touch a grounded metal object to dissipate any static charge that may be present on you.
- Only handling circuit boards in ESD safe areas, which may include ESD floor and table mats, wrist strap stations and ESD safe lab coats.
- Avoiding handling circuit boards in carpeted areas.
- Try to handle the board by the edges, avoiding contact with components.

REVISION HISTORY

Revision	Date	Changes
0.00	2024-02-12	Preliminary Release
0.01	2024-03-07	Corrected the weight value in the product specification
0.02	2024-07-25	Updated the description for USB under Product Feature & Specifications
0.03	2024-12-23	Corrected NVMe supported sizes in P6 connector table

INTRODUCTION

Connect Tech’s Hadron GMSL platform brings a low cost deployable Jetson solution to the market. The design includes 2 x GMSL port with Power over Coaxial (PoC), 1x Gigabit Ethernet, 2 x USB 3.1 (when using NVIDIA® Jetson Orin™ NX), 4x GPIOs (2x PWM capable), 3x UART, 1x I2C, and 1x CAN.

Product Feature and Specifications

Feature	Description
Module Compatibility	NVIDIA® Jetson Orin™ NX (8GB, 16GB) NVIDIA® Jetson Orin™ Nano (4GB, 8GB)
Mechanical Dimensions	82.65mm x 68.8mm (3.25" x 2.71")
USB	2x USB 3.2 (10Gbps) <ul style="list-style-type: none"> 1x Host Only 1x Dual Function – Host / Device mode (Selectable by S1 switch) <p>Note – Dual Function port will be used when the system enters Force Recovery Mode</p>
GMSL	2x GMSL Coax Port <ul style="list-style-type: none"> Supports both GMSL1 and GMSL2 specifications User selectable 3Gbps or 6Gbps GMSL2 data rate User selectable HIM (High Immunity Mode) for GMSL1 Each GMSL port connected to a 4-lane CSI-2 PHY 12VDC, 500mA power through each port with PoC <p>Connector: MMCX-J-P-H-ST-TH1</p> <ul style="list-style-type: none"> Samtec MMCX Series 50-ohm RF connector
Storage	1x M.2 M-Key (NVMe) expansion slot (4 lane PCIe Gen 4) Support for 2242 sized NVMe SSD
IO – Ethernet	1x 10/100/1000BASE-T Uplink
IO – UART Debug	1x Debug UART (I/O header)
IO – UART	2x RS-232 (I/O header)
IO – I2C	1x I2C Bus (I/O header)
IO – CAN	1x Non-isolated CAN Bus (I/O header)
IO – GPIO / PWM	4x GPIO (I/O header) – 2x PWM Capable

User Expansion	1x M.2 Key-E Expansion Slot (1 lane PCIe Gen 3, USB 2.0) For WiFi/Bluetooth modules
RTC Battery	3-Pin RTC Battery Connector
Input Power	+9V to +60V DC Wide Input Power (4-pin Molex Micro-Fit+ Connector)
Operating Temperature	-25°C to +85°C (-13°F to +185°F)
Weight	58 grams
Warranty and Support	1 Year Warranty and Free Support

Part Numbers / Ordering Information

Part Number	Description
NGX018	Hadron GMSL Carrier

PRODUCT OVERVIEW

Block Diagram

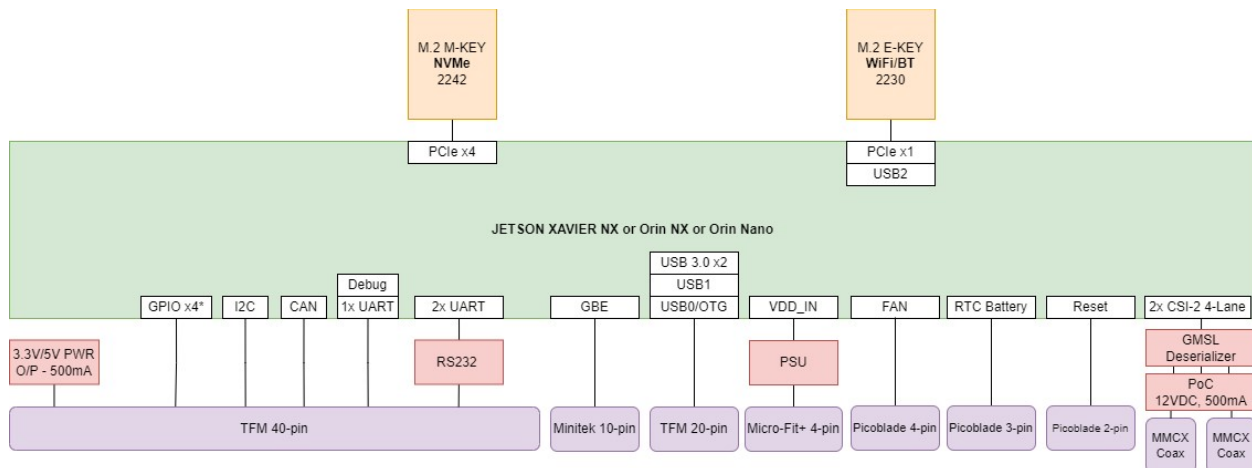

Connector Summary

Designator	Connector	Description
P1	2309413-1	Module Board-To-Board Connector for: <ul style="list-style-type: none"> • NVIDIA® Jetson Orin™ NX • NVIDIA® Jetson Orin™ Nano
P2	98414-G06-10LF	GbE Connector
P3	TFM-110-02-L-D-WT	Dual Port USB 3.0 Connector
P4	TFM-120-02-L-D-WT	I/O Header
P5	10128797-004RLF	M.2 E-Key Connector
P6	10131758-001RLF	M.2 M-Key (NVMe) Connector
P7, P11	MMCX-J-P-H-ST-TH1	MMCX Series 50-ohm RF connector
P8	1053101104	Input Power Connector
P9	53047-0310	3-pin RTC Battery Connector
P10	53047-0410	5V Fan Connector
P12	53047-0210	Force Recovery / Reset Connector

Switch Summary

Designator	Switch	Description
S1	1571983-1	Host Mode / Device Mode Selection Switch
S2		CAN BUS 120-Ohm Termination Resistor Enable/Disable
S3		GMSL Mode Selection Switch

DETAILED FEATURE DESCRIPTION

Jetson Orin™ NX / Orin™ Nano Module Connector

Description

The NVIDIA® Jetson Orin™ NX / Orin™ Nano processor and chipset are implemented on the Jetson Orin™ NX / Orin™ Nano modules. This connects to the Hadron Carrier via a TE Connectivity DDR4 SODIMM 260 Pin connector.

Function	Description
Location	P1
Type	TE Connectivity DDR4 SODIMM 260 Pin
Carrier Connector	Part Number: 2309413-1 Manufacturer: TE Connectivity
Mating Connector	Jetson Orin™ NX / Orin™ Nano
Pinout	Refer to NVIDIA®'s Jetson Orin™ NX / Orin™ Nano System-On-Module datasheet for pinout details https://developer.nvidia.com/embedded/downloads
Board-to-Module Standoff Height	M2.5 x 6.57mm standoffs required between NVIDIA® Jetson Orin™ NX / Orin™ Nano Module and Hadron GMSL Carrier

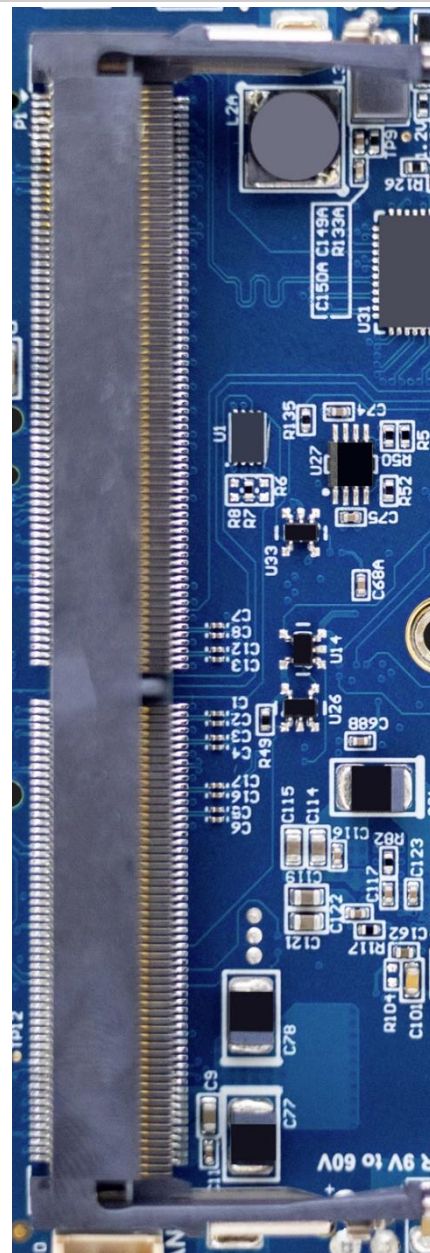

10/100/1000 Ethernet Connectors

Description

The NVIDIA® Jetson Orin™ NX / Orin™ Nano module will allow internet communication via GbE connector as below.

Function	Description
Location	P2
Ethernet Usage	Jetson Onboard Ethernet
Type	10 pin RA connector
Carrier Connector	Part Number: 98414-G06-10LF Manufacturer: Amphenol ICC
Mating Connector	90311-010LF
Mating CTI Cable	CBG117
Pinout	
Pin 1	MDI0_N
Pin 2	MDI0_P
Pin 3	MDI1_N
Pin 4	MDI1_P
Pin 5	GBE_GND (Shield)
Pin 6	GBE_GND (Shield)
Pin 7	MDI2_N
Pin 8	MDI2_P
Pin 9	MDI3_N
Pin 10	MDI3_P

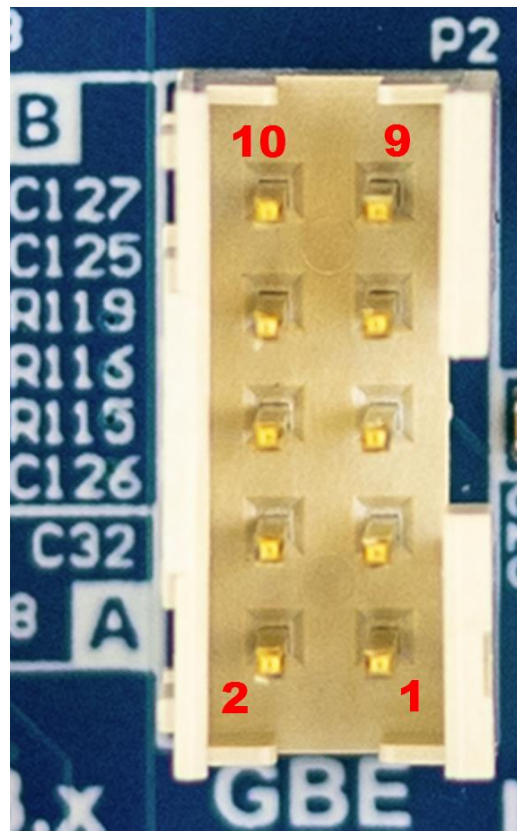

USB 3.1 Connector

Function	Description
Location	P3
Type	Tiger Eye 20 Pin Connector, 0.05mm Pitch
Carrier Connector	Part Number: TFM-110-02-L-D-WT Manufacturer: Samtec
Mating Cables	CBG615 (USB 2.0 ONLY), CBG686 (USB3.0)
Pinout	
Pin 1	GND
Pin 2	USB1_D_P
Pin 3	USB0_D_P
Pin 4	USB1_D_N
Pin 5	USB0_D_N
Pin 6	GND
Pin 7	GND
Pin 8	USB3_P1_TX_P
Pin 9	USB3_P0_TX_P
Pin 10	USB3_P1_TX_N
Pin 11	USB3_P0_TX_N
Pin 12	GND
Pin 13	GND
Pin 14	USB3_P1_RX_P
Pin 15	USB3_P0_RX_P
Pin 16	USB3_P1_RX_N
Pin 17	USB3_P0_RX_N
Pin 18	USB1 VBUS
Pin 19	USB0 VBUS
Pin 20	GND
Notes	Both ports will be USB 3.1 capable when using Jetson Orin™ NX / Orin™ Nano Maximum power available per USB port is 2A (10W):



I/O Header

Description

The Hadron Carrier implements a TFM-120-02-L-D-WT Connector to allow access for additional GPIO and interfaces.

Function		Description			
Location		P4			
Type		Samtec 40Pin Connector, 1.27mm Pitch			
Carrier Connector		Part Number: TFM-120-02-L-D-WT Manufacturer: Samtec			
Mating Cable/Connector		CBG629 / SFSD-20-28C-G-12.00-SR Manufacturer: Samtec			
Pinout					
Description	Signal Name	Pins	Signal Name	Description	
Signal Ground	GND	1 2	GND	Signal Ground	
GPIO10	GPIO10	3 4	GPIO13	GPIO13 (PWM)	
GPIO11	GPIO11	5 6	GPIO12	GPIO12 (PWM)	
Signal Ground	GND	7 8	GND	Signal Ground	
+5V Power Out ¹	+5V_IO	9 10	+3.3V_IO	+3.3V Power Out ¹	
+5V Power Out ¹	+5V_IO	11 12	+3.3V_IO	+3.3V Power Out ¹	
Signal Ground	GND	13 14	GND	Signal Ground	
Unused / No Connections	NC	15 16	CAN_L	CAN Low Side Differential Data	
Unused / No Connections	NC	17 18	CAN_H	CAN High Side Differential Data	
Signal Ground	GND	19 20	GND	Signal Ground	
RS-232_0 Request to Send	RS-232_0_RTS	21 22	RS-232_0_TX	RS-232_0 Transmit	
RS-232_0 Clear to Send	RS-232_0_CTS	23 24	RS-232_0_RX	RS-232_0 Receive	
Signal Ground	GND	25 26	GND	Signal Ground	
RS-232_1 Transmit	RS-232_1_TX	27 28	RS-232_1_RTS	RS-232_1 Request to Send	
RS-232_1 Receive	RS-232_1_RX	29 30	RS-232_1_CTS	RS-232_1 Clear to Send	
Signal Ground	GND	31 32	GND	Signal Ground	
I2C0 Clock	I2C 0 SCL	33 34	I2C 0 SDA	I2C0 Data	
Signal Ground	GND	35 36	GND	Signal Ground	
Debug UART RX	UART2_RX	37 38	UART2_TX	Debug UART TX	
Signal Ground	GND	39 40	GND	Signal Ground	

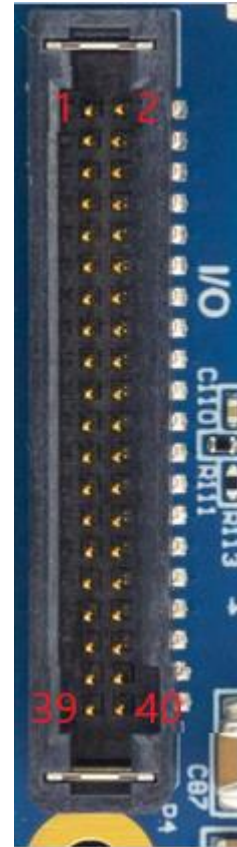

Orin™ NX SW Interface cross Reference		
Signal Name	Module ID	Controller ID
GPIO10	GPIO10	PEE.02
GPIO11	GPIO11	PQ.06
GPIO12	GPIO12	PN.01
GPIO13 (PWM)	32c0000.pwm	pwmchip2
GPIO12 (PWM)	3280000.pwm	pwmchip0

Signal Name	SW/Dev ID	DTB ID
I2C0	i2c-1	I2c@c240000
RS232_0	/dev/ttyTHS1	serial@3110000
RS232_1	/dev/ttyTHS0	serial@3100000
CAN	can0	mttcan@c310000

Notes

- +3.3V and +5V power pins are outputs only, **DO NOT** feed power to these pins
- GPIO, I2C, and Debug-UART are 3.3V logic

M.2 E-Key – WiFi and Bluetooth Expansion Port

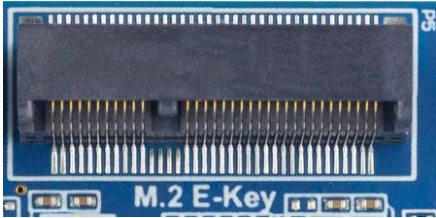
Function	Description	
Location	P5	
Type	67 Pin M.2 Connector with M2.5 Mounting Standoff	
Connector	Part Number: 10128797-004RLF Manufacturer: Amphenol ICC	
Pinout	As per the M.2 E-key specification	
Notes	This port contains a x1 PCIe Gen 1 interface and one USB 2.0 interface. * PCIe Gen# is based on available equipment and their testing with Hadron GMSL Carrier.	

M.2 M-Key – NVMe

Function	Description	
Location	P6	
Type	67 Pin M.2 Connector with M2.5 Mounting Standoff	
Connector	Part Number: 10131758-001RLF Manufacturer: Amphenol ICC	
Pinout	As per the M.2 E-key specification	
Notes	Interface is x4 PCIe Gen 4. Support for M.2 2242 size only. * PCIe Gen# is based on available equipment and their testing with Hadron GMSL Carrier.	

GMSL Coax Connectors

Description

The NVIDIA® Jetson Orin™ NX / Orin™ Nano allows for two 4-Lane MIPI video input. In this mode, CSI0 and CSI1 are combined to form the 4-lane MIPI; same goes for CSI2 and CSI3. The MAX9296A Deserializer chip takes the two GMSL serial inputs and converts it to the two 4-lane MIPI input for the NVIDIA® module.

Function	Description
Location	P7, P11
MIPI Lane usage	CSI0 + CSI1, CSI2 + CSI3
Coax Connector	Part Number: MMCX-J-P-H-ST-TH1 Manufacturer: Samtec
Type	50-ohm MMCX series Vertical RF connector
Mating CTI Cable	CBG619



Power Header

Description

The Hadron GMSL Carrier implements a Nano-Fit Power Connector using 1053101104 from Molex.

Function	Description
Location	P8
Type	Molex Nano-Fit
Carrier Connector	1053101104
Mating CTI Cable	CBG706
Pinout	
Pin 1	+VIN
Pin 2	+VIN
Pin 3	GND
Pin 4	GND

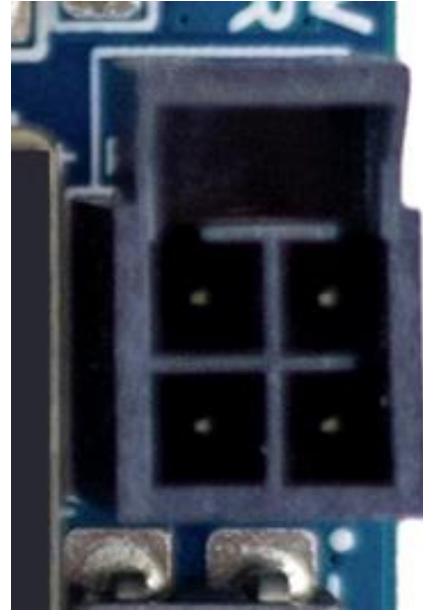

3-Pin RTC Battery Connector

Description

The Hadron Carrier implements a 3 Position Molex PicoBlade connector for connecting RTC battery.

Function	Description
Location	P9
Type	Molex 3 Position 1.25mm PicoBlade Connector
Carrier Connector	Part Number: 53047-0310 Manufacturer: Molex
Mating Connector	Molex 51021-0300 PicoBlade Connector
Mating CTI Cable	CBG136
Pinout	
Pin 1	RTC Battery Positive (+ve)
Pin 2	Not Connect
Pin 3	RTC Battery Negative (-ve)



+5V Fan Connector

Description

The Hadron Carrier implements a 4 Position Molex PicoBlade connector for active cooling capability.

Function	Description
Location	P10
Type	Molex 4 Position 1.25mm PicoBlade Connector
Carrier Connector	Part Number: 53047-0410 Manufacturer: Molex
Mating Connector	Molex 51021-0400 PicoBlade Connector
Pinout	



Pin 1	GND
Pin 2	+5V
Pin 3	FAN_TACH
Pin 4	FAN_PWM

Force Recovery / Reset Connector

Description

The Hadron GMSL Carrier implements a 2-position Molex PicoBlade connector for both Reset and Recovery of the platform. To reset the module, short the two pins on the connector momentarily. To put the Jetson module into Force Recovery mode, short the two pins and then power on the platform. After 10 seconds remove the short and the device will now be in Force Recovery mode. Once the device is in Force Recovery Mode, it can be detected using *lsusb* (or equivalent) command on the host computer. Note that a full power cycle of the system must be performed after module flashing

Function	Description
Location	P12
Type	Molex 2 Position 1.25mm PicoBlade Connector
Carrier Connector	Part Number: 53047-0210 Manufacturer: Molex
Mating Connector	Molex 510210200 PicoBlade Connector
Mating CTI Cable	CBG705
Pinout	
Pin 1	GND
Pin 2	Reset

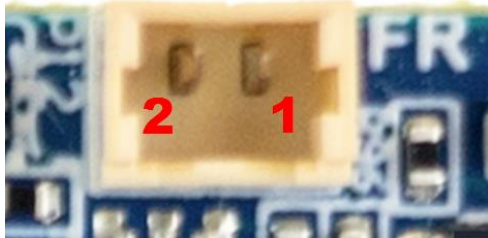

USB Host / Device Mode and Power Switch

Function	Description	
Location	S1	
Type	TE Connectivity 1571983-1 DIP Switch	
Carrier Connector	Part Number: 1571983-1 Manufacturer: TE Connectivity Product is shipped with both switches OFF	
S1-A	Manufacturing use ONLY. Leave in OFF position for proper operation.	
S1-B	On: USB Host Mode Off: USB Device Mode	

CAN BUS Termination Resistor

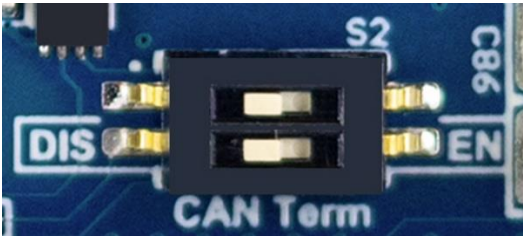
Function	Description	
Location	S2	
Type	TE Connectivity 1571983-1 DIP Switch	
Carrier Connector	Part Number: 1571983-1 Manufacturer: TE Connectivity Product is shipped with both switches OFF	
S2-A	Not Used.	
S2-B	On: 120-ohm termination resistor connected Off: No termination resistor	

GMSL Mode Select

Function	Description
Location	S3
Type	TE Connectivity 1571983-1 DIP Switch
Carrier Connector	Part Number: 1571983-1 Manufacturer: TE Connectivity Product is shipped with both switches OFF



GMSL Mode Select S3 Combinations

Please refer to the DIP Switch Position Table below to pick the GMSL mode desired.

S3-A	S3-B	Mode
0	0	GMSL1 HIM (High Immunity Mode ON)
0	1	GMSL2 6-Gbps
1	0	GMSL2 3-Gbps
1	1	GMSL1 (High Immunity Mode OFF)

LED Power Indicators

Description

The Hadron GMSL Carrier implements three LEDs (D14, D15, D16) for power status indication:

Function	Description
Location	D14, D15, D16
Type	Green LED
Function	LED
+5V	D14
Power Good	D15
SYS_ON	D16

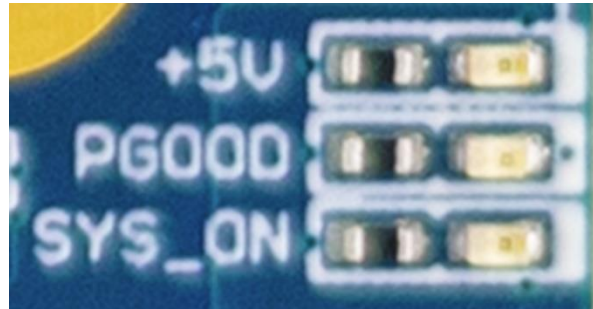

LED GMSL Status Indicators

Description

The Hadron GMSL Carrier implements two LEDs (D9, D10) for status indication of the GMSL Deserializer:

Function	Description
Location	D9, D10
Type	Green (D9) & Red (D10)
Function	LED
Lock	D9
Error	D10

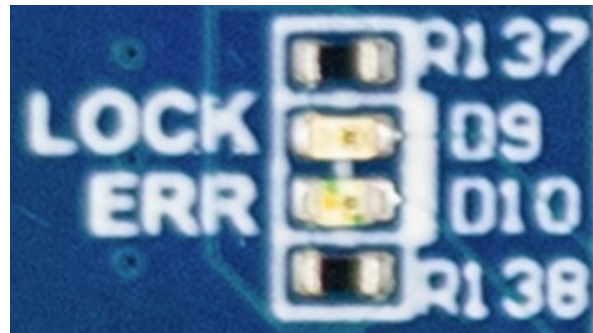

TYPICAL INSTALLATION

1. Ensure all external system power supplies are off and disconnected.
2. Install the NVIDIA® Jetson Orin™ NX / Orin™ Module into the DDR4 260 Pin SODIMM Connector (P1).

Be sure to follow the manufacturer's directions for proper installation of mounting hardware, heatsink / heat-spreader, and any other applicable requirements from the manufacturer.

3. Install the necessary cables based on your application:
 1. Connect Power cable to the input power connector (P8)
 2. Connect a 3.3V TTL FTDI Serial cable to UART2 pins on Pin 37 and Pin 38 of the I/O Header (P4)
 3. If network connectivity is required, plug-in CBG117 at P2

4. Connect the Power Cable of the Power Supply into the Power header (P8)

Plug the AC cable of the Power Supply into the wall.

5. Access the debug UART port using a standard 3.3V TTL FTDI cable to any computer over USB. Another TTL UART interface is required to use the debug port. The default serial settings are 115200 8N1 (standard settings) but hardware flow control must be turned off.

If using minicom in Linux based systems, serial into the system through disabling the hardware flow control:

1. Press CTRL+A
2. Press o
3. Go to Serial Port Setup
4. Press F (To change hardware flow control to off)
5. (optional) save as default in previous menu

If using putty in Windows based systems, in the left menu go to serial>flow control>None.

DO NOT power up your system by plugging in live power.

MECHANICAL DETAILS

Full 3D Models of all Hadron assemblies can be found here:

https://connecttech.com/ftp/3d_models/NGX018_3D_MODEL.zip

NGX018 – Hadron GMSL - Stand Alone Drawings

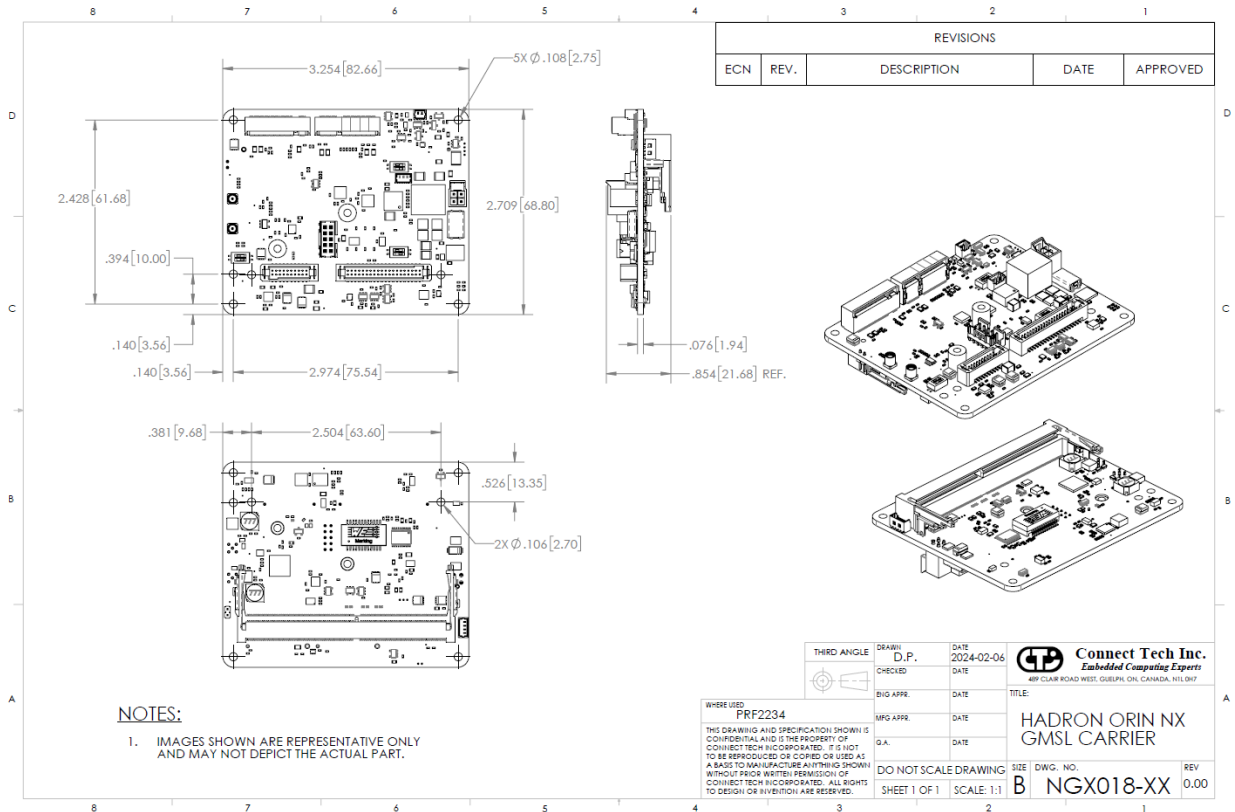

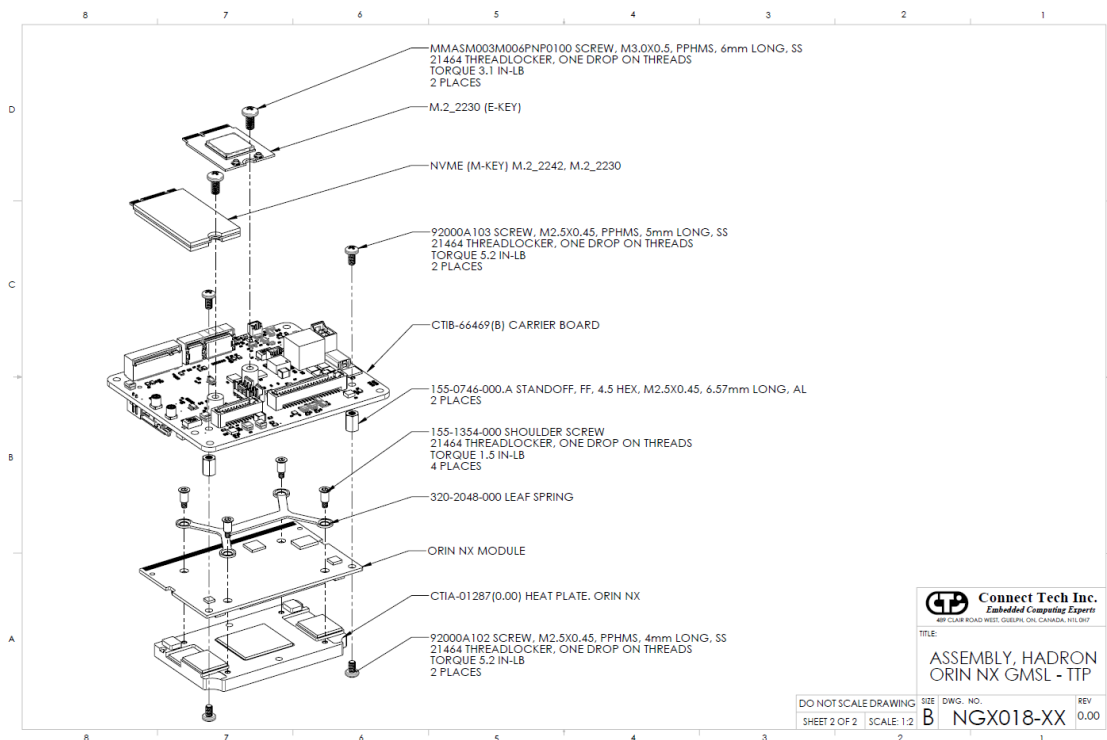
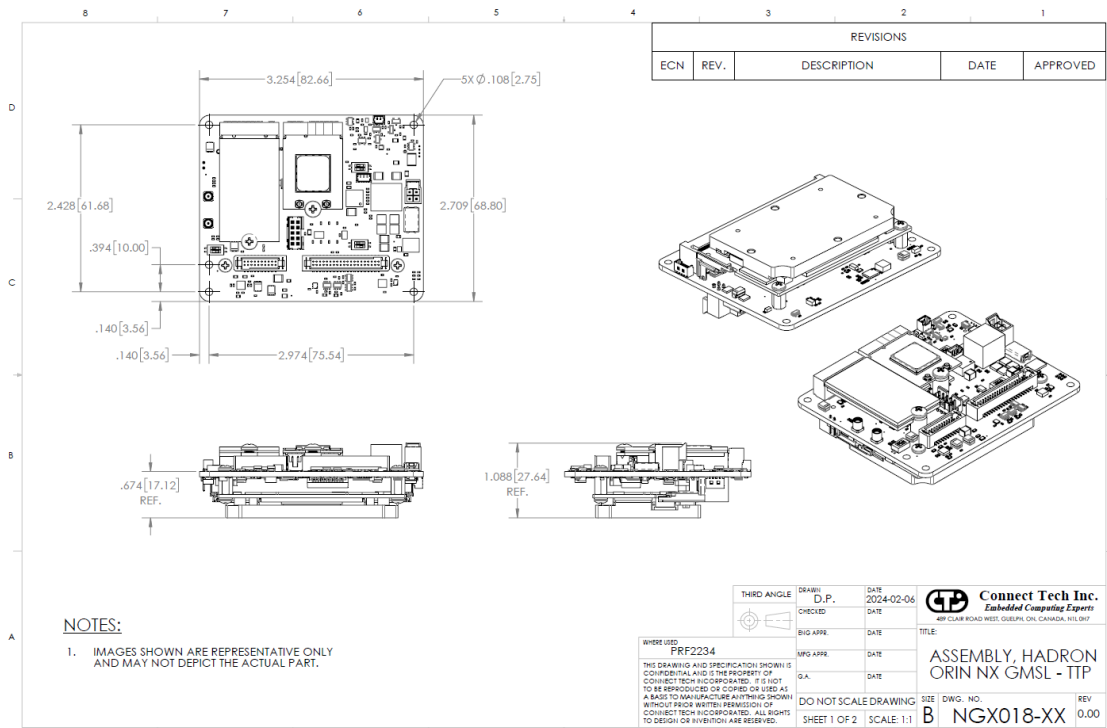
NGX018-XX – Hadron GMSL TTP Integration Details (w/ WiFi + 2242 NVMe)

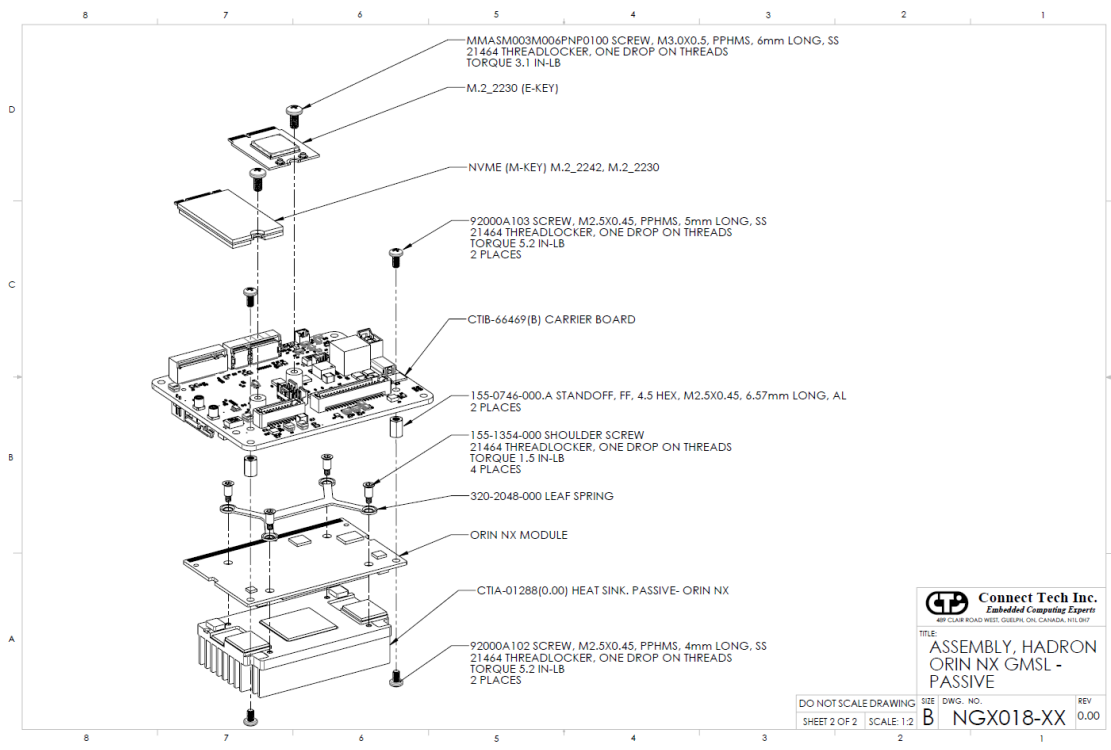
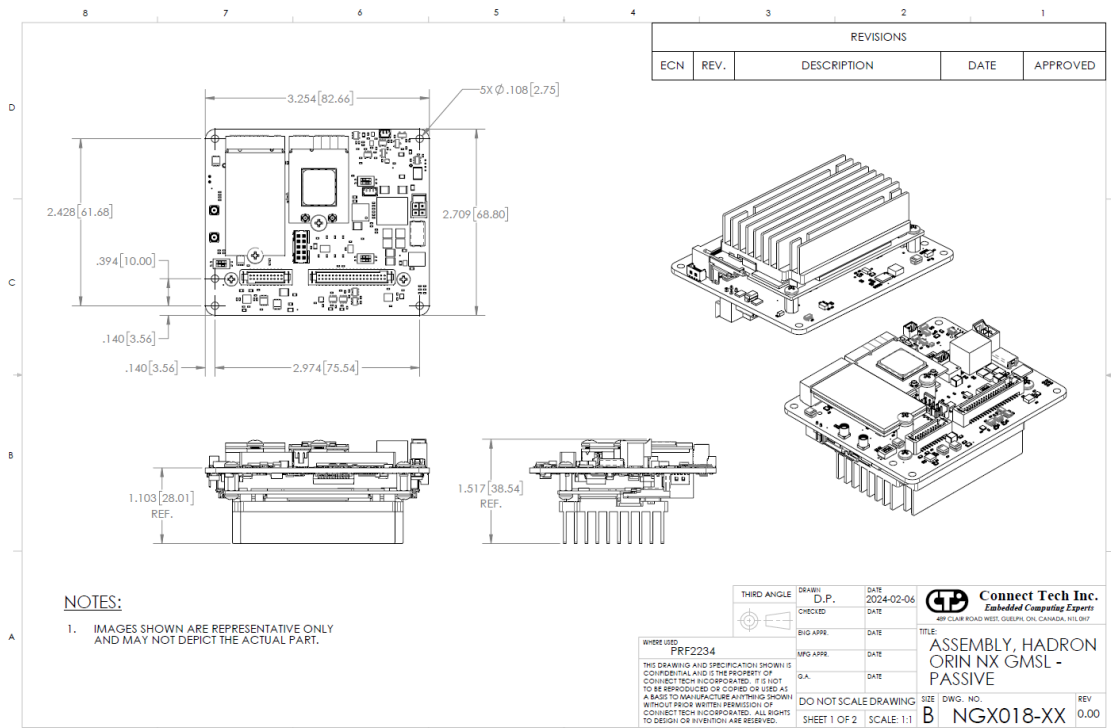
NGX018-XX – Hadron GMSL Passive Thermal Integration Details (w/ WiFi + 2242 NVMe)

NGX018-XX – Hadron GMSL Active Thermal Integration Details (w/ WiFi + 2242 NVMe)

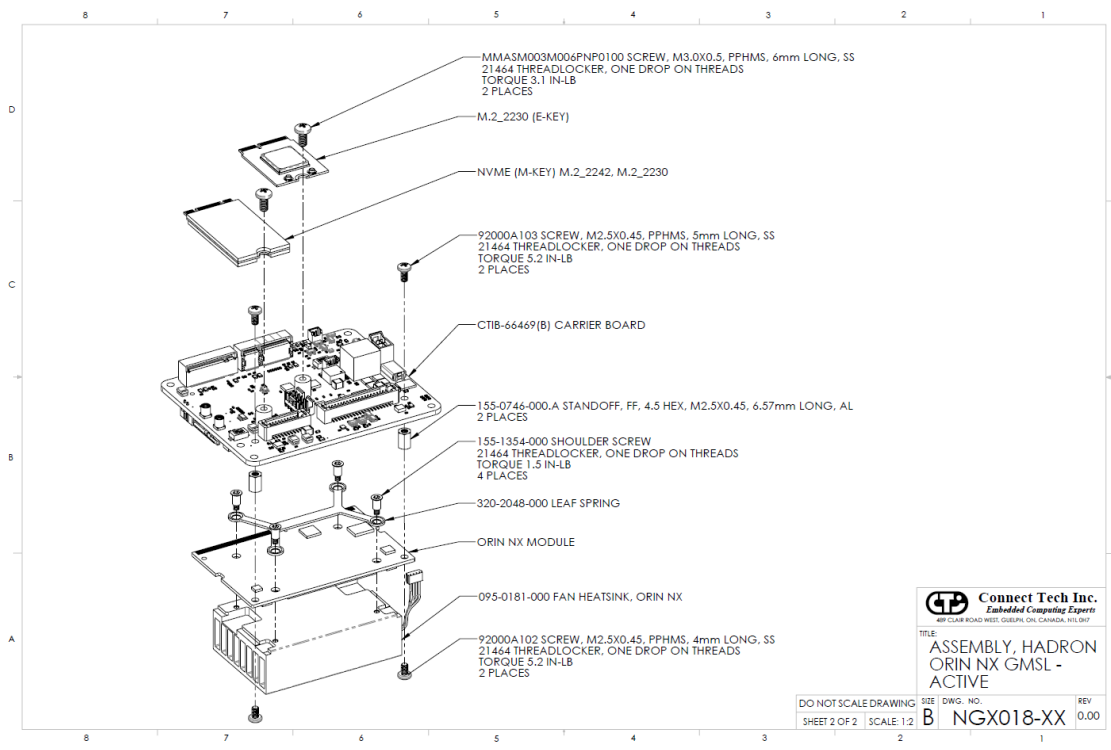
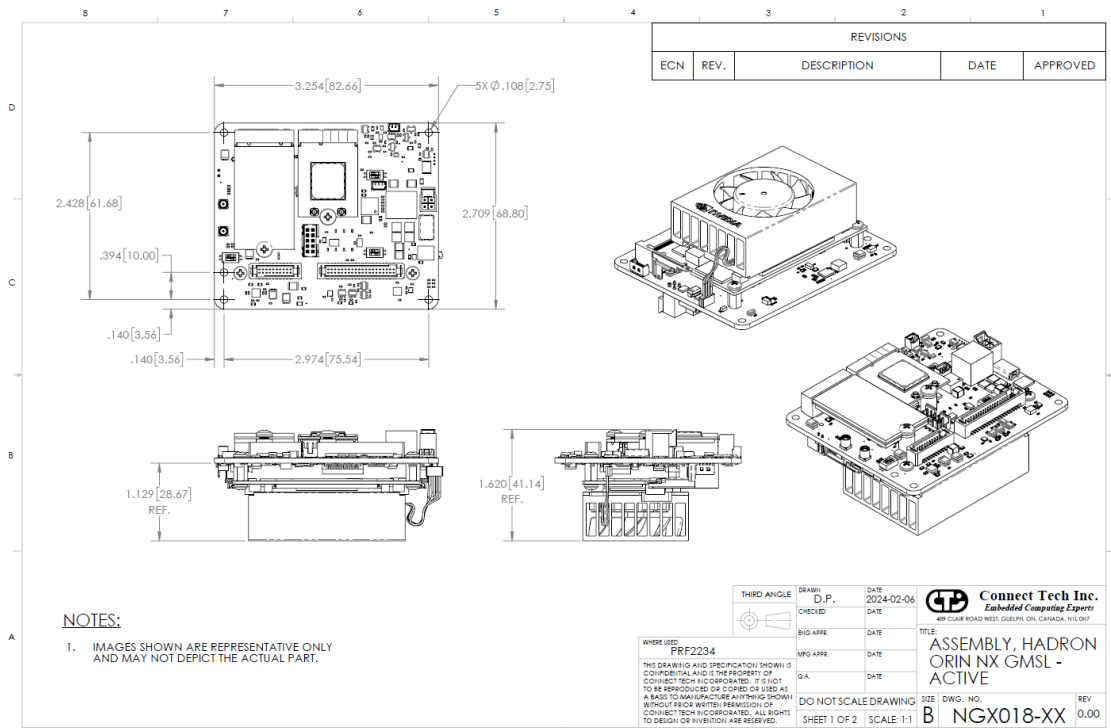

THERMAL DETAILS

The Hadron GMSL Carrier has an Operating Temperature Range of -25°C to +85°C.

However, it is important to note that the NVIDIA® Jetson Orin™ NX / Orin™ Module has its own properties separate to that of the Hadron Carrier. The Hadron GMSL is rated for Operating Temperature Range of -25°C to +85°C.

Customer responsibility requires proper implementation of a thermal solution that maintains the Hadron SoC and Thermal Transfer Plate (TTP) temperatures below the specified temperatures (shown in the tables below) under the maximum thermal load and system conditions for their use case.

NVIDIA® Jetson Orin™ NX

Parameter	Value	Units
Maximum Orin™ NX SoC Operating Temperature	T.cpu = 99	°C
	T.gpu = 99	°C
Orin™ NX SoC Shutdown Temperature	T.cpu = 105	°C
	T.gpu = 105	°C

CABLE INFORMATION

Drawing No.	Part No.	Function	Description
N/A	CBG706	Power Cable	Molex Nano-Fit 2x2 Off-the-Shelf Cable Assembly Molex Part Number: 451300410
<u>CTIC-00433</u>	CBG117	Ethernet Cable	10-pin MiniTek w/ Latch, RJ-45 Panel Mount
<u>CTIC-00477</u>	CBG136	RTC Battery Cable	Molex 3 position PicoBlade Connector to Coin Cell Battery
<u>CTIC-00864</u>	CBG705	Force Recovery and Reset	Molex 2 Position PicoBlade Connector to Panel Mount Pushbutton
N/A	CBG615	USB2.0 Cable	20-pin Tiger-Eye to 2x USB 2.0 Type-A Female
N/A	CBG686	USB3.0 Cable	20-pin Tiger-Eye to 2x USB 3.0 Type-A Female (200mm)
N/A	CBG629	I/O cable	40-pin Tiger-Eye to Unterminated Flying Leads Samtec Part Number: SFSD-20-28C-G12.00-SR
<u>CTIC-00802</u>	CBG619	GMSL Coax Cable	Samtec MMCX Plug to FAKRA Plug Z-Type IP67

Cable Components:

Below is the list of components required to assemble USB and I/O cable for Hadron carrier:

Component	USB Cable	I/O Cable
Connector Housing	ISDF-10-D-M	ISDF-20-D-M
Crimp Contact	CC03M-2830-GF	CC03M-2830-GF
Crimp Hand tool	CAT-HT-203-2830-12	CAT-HT-203-2830-12
Wire Gauge	28 – 30 AWG	28 – 30 AWG
Notes	USB Differential pairs needs to be twisted pairs	3.3V and 5V output is limited to 500mA each on Rev B and newer

CONNECT TECH CUSTOM THERMAL SOLUTIONS

Connect Tech Inc. has three custom solutions available for customer implementation, namely, an Active Cooling Solution, Passive Cooling Solution, and Thermal Transfer Plate Solution. Please note the different part numbers for NVIDIA® Jetson Orin™ NX / Orin™ Nano thermal solutions.

Connect Tech Inc. NVIDIA® Jetson Orin™ NX / Orin™ Nano Thermal Solutions

Function	Part Number
Orin NX / Nano - Active Heatsink	XHG325
Orin NX / Nano - Passive Heatsink	XHG324
Orin NX / Nano - Thermal Transfer Plate	XHG323

POWER CONSUMPTION DETAILS

Tested with 9V DC input

NVIDIA® Jetson Orin™ NX

Parameter	Value	Units	Temperature
NVIDIA® Jetson Orin™ NX Module 16GB, Active Cooling, Idle, Ethernet, two cameras (IMX390), Mouse and Keyboard plugged in	8.5	W	25°C (typ.)
NVIDIA® Jetson Orin™ NX Module 16GB, Active Cooling, MAXN mode (7 cores full load, 1 core for CPU stress utility), CPU-stressed, GPU-stressed, Ethernet, Mouse and Keyboard plugged in	28.1	W	25°C (typ.)
NVIDIA® Jetson Orin™ NX Module 16GB, Active Cooling, MAXN mode (7 cores full load, 1 core for CPU stress utility), CPU-stressed, GPU-stressed, Ethernet, 2 Full HD Video Streams, Mouse and Keyboard plugged in	31.5	W	25°C (typ.)

SOFTWARE / BSP DETAILS

All Connect Tech NVIDIA® Jetson based products are built upon a modified Linux for Tegra (L4T) Device Tree that is specific to each CTI product.

WARNING: The hardware configurations of CTI's products differ from that of the NVIDIA® supplied evaluation kit. Please review the product documentation and install ONLY the appropriate CTI L4T BSPs. Failure to follow this process could result in non-functional hardware.