

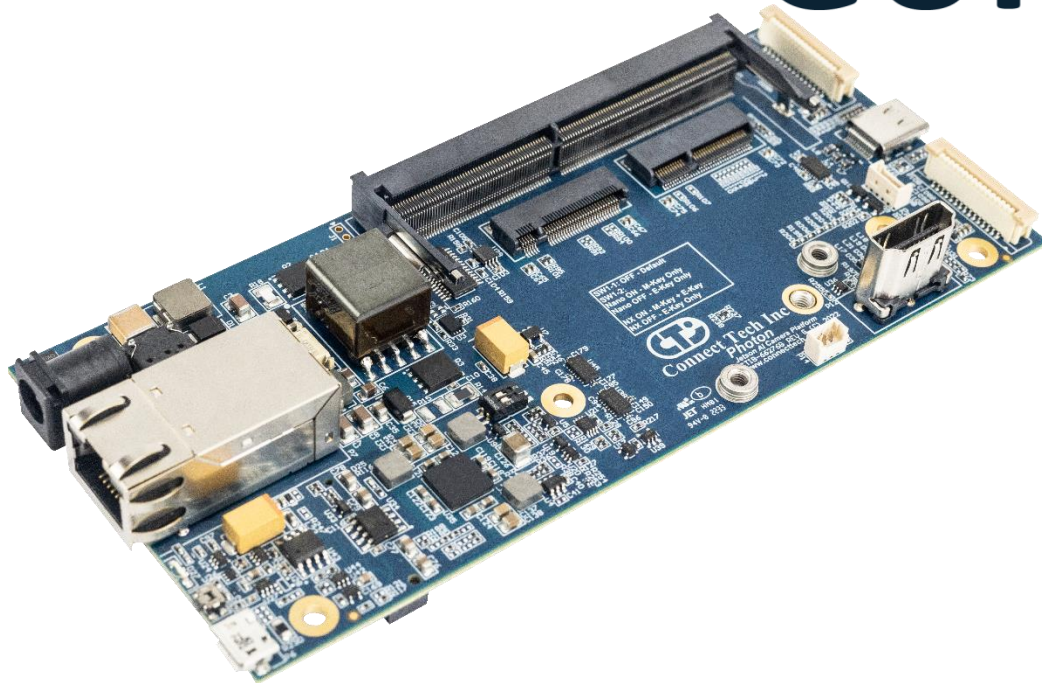

**Connect Tech Inc.**  
Embedded Computing Experts

# USERS GUIDE



## Photon AI Camera Platform

CTIM-00080 Revision 0.08 2023-06-30



CONNECT TECH

[www.connecttech.com](http://www.connecttech.com)

[support@connecttech.com](mailto:support@connecttech.com)

## TABLE OF CONTENTS

<b>Table of Contents .....</b>	<b>2</b>
<b>Preface .....</b>	<b>4</b>
Disclaimer.....	4
Customer Support Overview .....	4
Contact Information.....	4
Limited Product Warranty .....	5
Copyright Notice .....	5
Trademark Acknowledgment .....	5
ESD Warning.....	6
<b>Revision History .....</b>	<b>6</b>
<b>Introduction.....</b>	<b>7</b>
Product Features and Specifications .....	7
Part Numbers / Ordering Information.....	8
<b>Product Overview.....</b>	<b>8</b>
Block Diagram.....	8
Connector Locations.....	10
Connector Summary .....	12
LED, Jumper & Switch Summary .....	13
<b>Detailed Feature Description.....</b>	<b>14</b>
Jetson Module Connector .....	14
USB 2.0 OTG/Host Mode Connector.....	15
USB 2.0 FTDI Console Connector .....	15
HDMI Connector.....	16
12V Barrel Jack Connector.....	16
GBE RJ45 Ethernet & PoE PD Connector .....	17
MIPI CSI-2 Connectors .....	18
M.2 B-Key Connector .....	19
M.2 E-Key Connector.....	19
M.2 M-Key Connector .....	20
Dual microSD Card/ Module SIM Card Connector .....	20
5V Fan Connector.....	21
RTC Battery Connector.....	21
I2C/GPIO/Power Connector.....	22
Reset & Recovery Pushbutton .....	23
M.2 M-Key / M.2 E-Key DIP Switch Selection .....	23
PWM RGB LED.....	24
USB 3.0 Type-C Connector.....	24
<b>PoE PD and Grounding during hot plug events .....</b>	<b>26</b>
<b>Grounding Notes .....</b>	<b>27</b>
<b>Software Setup.....</b>	<b>28</b>
<b>Optional integration features .....</b>	<b>28</b>
<b>Power Consumption &amp; Thermals .....</b>	<b>29</b>

Thermal Details .....	29
Connect Tech Custom Thermal Solutions .....	30
<b>Current Consumption Details .....</b>	<b>32</b>

## PREFACE

### Disclaimer

The information contained within this user's guide, including but not limited to any product specification, is subject to change without notice.

Connect Tech assumes no liability for any damages incurred directly or indirectly from any technical or typographical errors or omissions contained herein or for discrepancies between the product and the user's guide.

### Customer Support Overview

If you experience difficulties after reading the manual and/or using the product, contact the Connect Tech reseller from which you purchased the product. In most cases the reseller can help you with product installation and difficulties.

In the event that the reseller is unable to resolve your problem, our highly qualified support staff can assist you. Our support section is available 24 hours a day, 7 days a week on our website at: <https://connecttech.com/support/resource-center/>. See the contact information section below for more information on how to contact us directly. Our technical support is always free.

### Contact Information

Contact Information	
<b>Mail/Courier</b>	Connect Tech Inc. Technical Support 489 Clair Road West Guelph, Ontario Canada N1L 0H7
<b>Contact Information</b>	<a href="mailto:sales@connecttech.com">sales@connecttech.com</a> <a href="mailto:support@connecttech.com">support@connecttech.com</a> <a href="http://www.connecttech.com">www.connecttech.com</a>  Toll Free: 800-426-8979 (North America only) Telephone: +1-519-836-1291 Facsimile: 519-836-4878 (on-line 24 hours)
<b>Support</b>	Please go to the <a href="#">Connect Tech Resource Center</a> for product manuals, installation guides, device drivers, BSPs and technical tips.  Submit your <a href="#">technical support</a> questions to our support engineers. Technical Support representatives are available Monday through Friday, from 8:30 a.m. to 5:00 p.m. Eastern Standard Time.

## Limited Product Warranty

Connect Tech Inc. provides a one year Warranty for this product. Should this product, in Connect Tech Inc.'s opinion, fail to be in good working order during the warranty period, Connect Tech Inc. will, at its option, repair or replace this product at no charge, provided that the product has not been subjected to abuse, misuse, accident, disaster or non-Connect Tech Inc. authorized modification or repair.

You may obtain warranty service by delivering this product to an authorized Connect Tech Inc. business partner or to Connect Tech Inc. along with proof of purchase. Product returned to Connect Tech Inc. must be pre-authorized by Connect Tech Inc. with an RMA (Return Material Authorization) number marked on the outside of the package and sent prepaid, insured and packaged for safe shipment. Connect Tech Inc. will return this product by prepaid ground shipment service.

The Connect Tech Inc. Limited Warranty is only valid over the serviceable life of the product. This is defined as the period during which all components are available. Should the product prove to be irreparable, Connect Tech Inc. reserves the right to substitute an equivalent product if available or to retract the Warranty if no replacement is available.

The above warranty is the only warranty authorized by Connect Tech Inc. Under no circumstances will Connect Tech Inc. be liable in any way for any damages, including any lost profits, lost savings or other incidental or consequential damages arising out of the use of, or inability to use, such product.

## Copyright Notice

The information contained in this document is subject to change without notice. Connect Tech Inc. shall not be liable for errors contained herein or for incidental consequential damages in connection with the furnishing, performance, or use of this material. This document contains proprietary information that is protected by copyright. All rights are reserved. No part of this document may be photocopied, reproduced, or translated to another language without the prior written consent of Connect Tech, Inc.

Copyright © 2021 by Connect Tech Inc.

## Trademark Acknowledgment

Connect Tech, Inc. acknowledges all trademarks, registered trademarks and/or copyrights referred to in this document as the property of their respective owners. Not listing all possible trademarks or copyright acknowledgments does not constitute a lack of acknowledgment to the rightful owners of the trademarks and copyrights mentioned in this document.

## ESD Warning



Electronic components and circuits are sensitive to ElectroStatic Discharge (ESD). When handling any circuit board assemblies including Connect Tech COM Express carrier assemblies, it is recommended that ESD safety precautions be observed. ESD safe best practices include, but are not limited to:

- Leaving circuit boards in their antistatic packaging until they are ready to be installed.
- Using a grounded wrist strap when handling circuit boards, at a minimum you should touch a grounded metal object to dissipate any static charge that may be present on you.
- Only handling circuit boards in ESD safe areas, which may include ESD floor and table mats, wrist strap stations and ESD safe lab coats.
- Avoiding handling circuit boards in carpeted areas.
- Try to handle the board by the edges, avoiding contact with components.

## REVISION HISTORY

Revision	Date	Changes
0.00	2020-01-16	Preliminary Release
0.01	2020-11-11	Updated Board Pictures, Updated Features
0.02	2020-11-13	Updated WiFi/BT Feature Module Information
0.03	2020-12-04	Updated WiFi/BT Feature Module Information, Updated Current Consumption Details
0.04	2021-02-22	Added input voltage tolerance
0.05	2021-08-05	Revision F Feature changes
0.06	2021-08-20	Manual corrections and additional information
0.07	2022-08-05	Updated PoE precautions and grounding schemes and Revision G notes
0.08	2023-06-30	Updated PCIe DIP Switch information for Revision G

## INTRODUCTION

### Product Features and Specifications

Specifications	
<b>Module Compatibility</b>	NVIDIA® Jetson Nano™ ( <b>PRODUCTION MODULE ONLY</b> ) NVIDIA® Jetson Xavier™ NX ( <b>PRODUCTION MODULE ONLY</b> ) NVIDIA® Jetson TX2™ NX
<b>Mechanical Dimensions</b>	145mm x 64.5mm
<b>USB Camera</b>	1x USB 3.0 (Connector: USB Type-C)
<b>MIPI Cameras</b>	2x 2-lane MIPI CSI-2 Connector: 1-1734248-5 15-pin FPC 1mm Pitch Connector  Please refer to our <a href="#">Jetson Supported Cameras Page</a> for more information
<b>Camera Misc Interface</b>	1x I2C (Can be used for Lens Control) 4x GPIO (Can be used for Additional Camera Control) 1x Power Output (Can be used for IR LEDs)
<b>Internal Debug Ports</b>	1x HDMI Display Output
<b>Storage</b>	1x microSD Card Slot 1x NVMe Slot (M.2 2280 M-KEY PCIe Based)
<b>Wireless Expansion</b>	1x WiFi Module (M.2 2230 E-KEY) 1x LTE Module (M.2 3042 B-KEY) w/ SIM Card Slot
<b>Rear IO – Ethernet</b> Please refer to this <a href="#">section</a> for installation instructions for PoE PD	1x 10/100/1000BASE-T Uplink PoE IEEE 802.3af-2003 (15.4W) Powered Device (PD) PoE+ IEEE 802.3at-2009 (25.5W) Powered Device (PD) Capable of operating on either network  Low Cost PoE Bypass Option Available ( <b>NGX003</b> )
<b>Rear IO – USB OTG</b>	1x USB 2.0 OTG for Flashing Capability (Micro USB)
<b>Rear IO – USB UART</b>	1x USB FTDI UART (Micro USB)
<b>Rear IO – Power Input</b>	1x 2.1mm DC Barrel Jack (+12V DC +/-5%)
<b>Rear IO – User Feedback</b>	1x RGB LED
<b>Rear IO - Button</b>	Dual RESET + FLASH Enable Functionality
<b>Operating Temperature</b>	-25°C to +85°C (-13°F to +185°F)
<b>Weight</b>	76g (0.167lbs)
<b>Warranty and Support</b>	1 Year Warranty and Free Support

Connect Tech’s Photon AI Camera Platform brings a low cost deployable Jetson solution to the market. Its design includes Power over Ethernet (PoE) 802.3at as well as a lower cost variant without it.

## Part Numbers / Ordering Information

Part Number	
NGX002	Photon AI Camera Platform w/ PoE PD
NGX003	Photon AI Camera Platform w/ No-PoE PD

## PRODUCT OVERVIEW

### Block Diagram

Revision G+

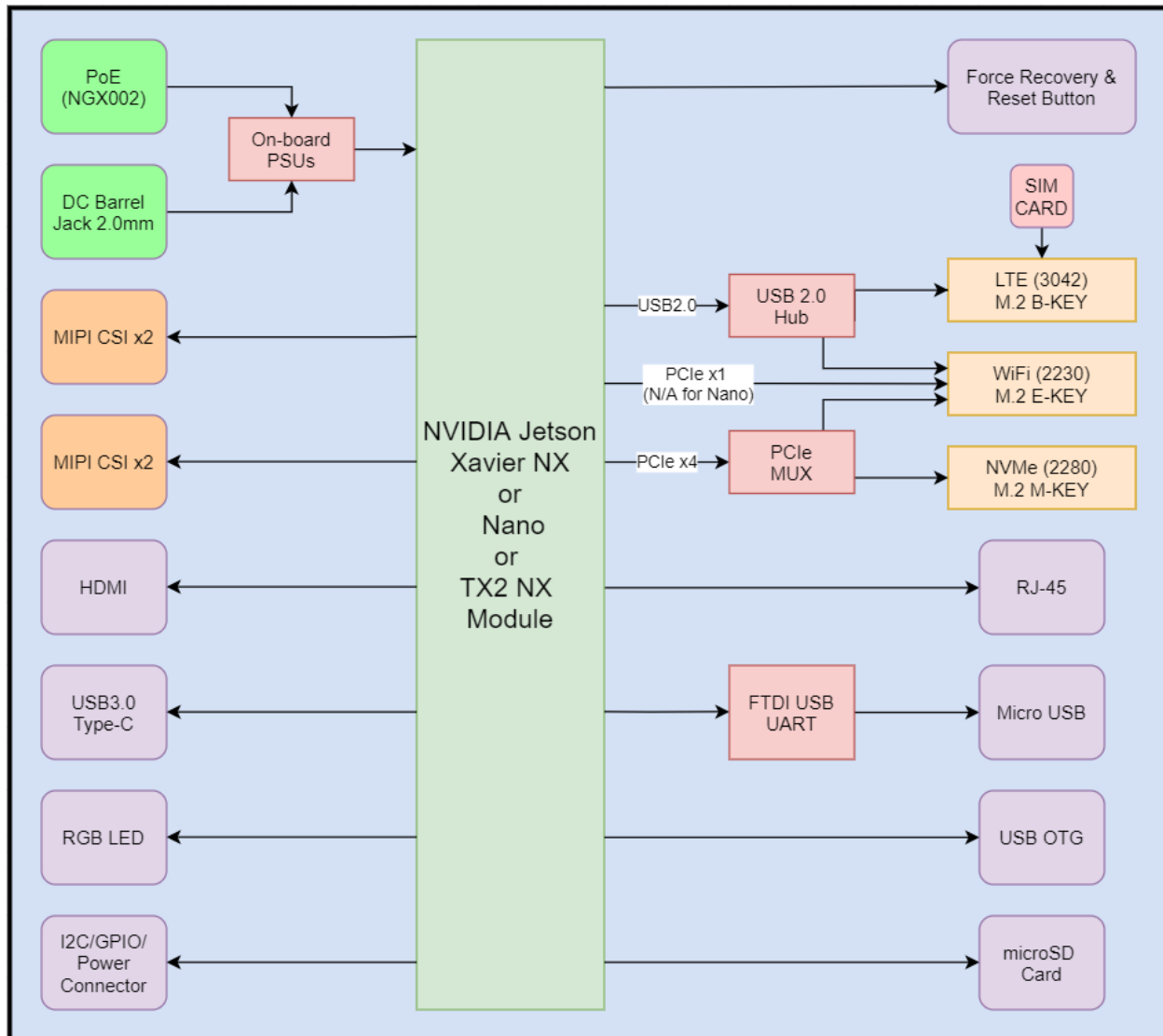

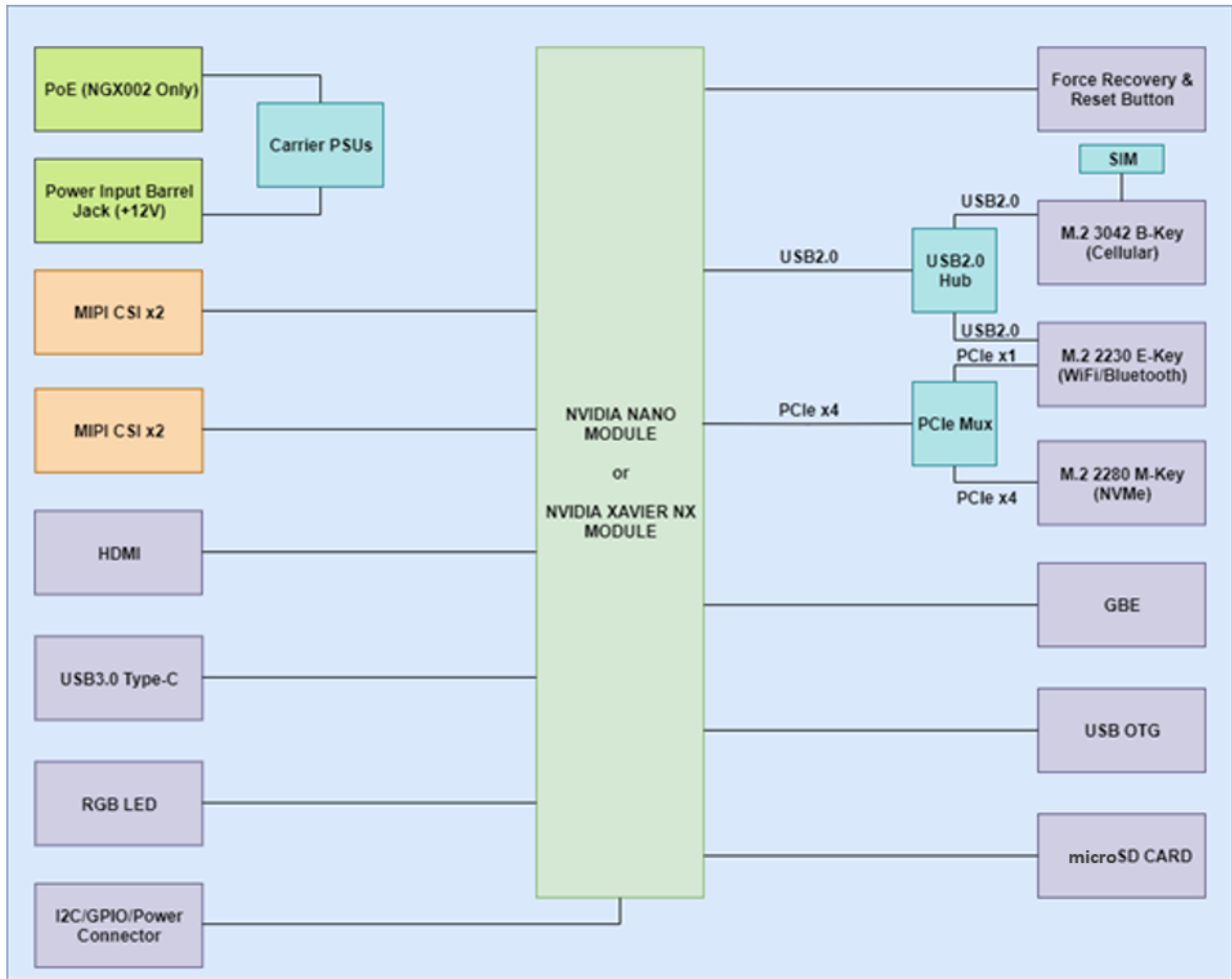
**Revision A-F**

## Connector Locations

### TOP VIEW

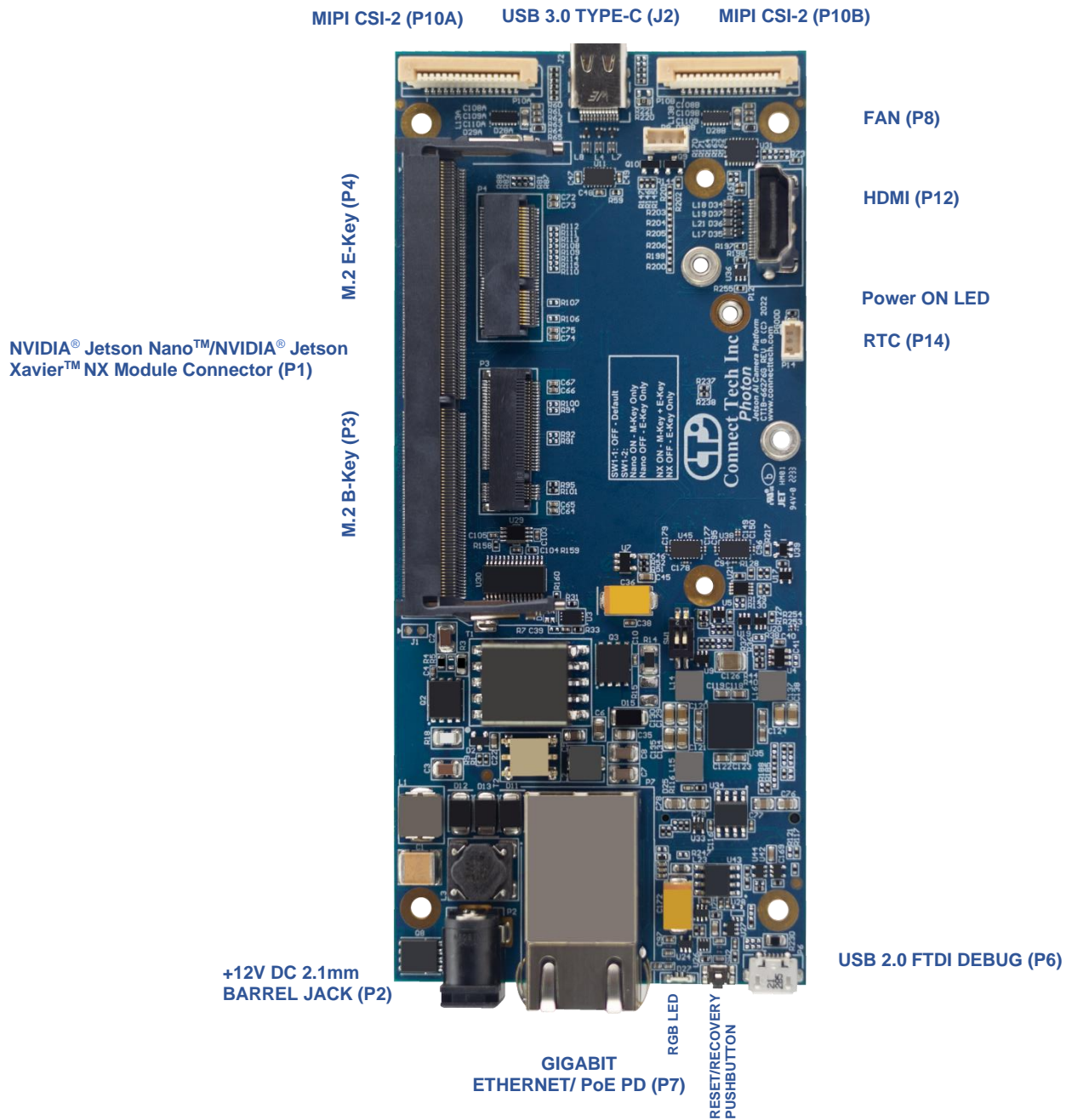



## Connector Summary

Designator	Connector	Description
P1	2309413-1	Module Board-To-Board Connector
P2	PJ-002A	+12V DC 2.1mm Barrel Jack Connector
P3	SM3ZS067U310ABR1200	M.2 3042 B-Key 2G/3G/LTE Cellular Module Connector
P4	2199119-4	M.2 2230 E-Key WiFi/Bluetooth Module Connector
P5	SM3ZS067U410AMR1000	M.2 2280 M-Key NVMe SSD Connector
P6	1981568-1	USB 2.0 Micro-B FTDI Console Debug Connector
P7	JXK0-0190NL	RJ-45 Gigabit Ethernet Connector
P8	53047-0410	+5V 4-Position Molex 1.25mm PicoBlade Fan Connector
P9	SM09B-NSHSS-TB	I2C/GPIO/LED JST Connector
P10A	52610-1572	MIPI CSI-2 Camera Connector
P10B	52610-1572	MIPI CSI-2 Camera Connector
P11	1042391430	Dual microSD/SIM Connector
P12	0476591000	HDMI Video Connector
P13	47589-0001	USB 2.0 Micro-AB OTG Connector
P14	53047-0310	RTC Battery Connector

## LED, Jumper & Switch Summary

The switches and jumpers should be set correctly before power up.



**WARNING:** With the NGX002, if connecting and powering via Power Over Ethernet PD connection and connecting the USB2.0 FTDI debug console (P6), GPIO (P9), HDMI (P12), USB 2.0 OTG (P13) – please refer to this [section](#) to avoid damage to product and equipment

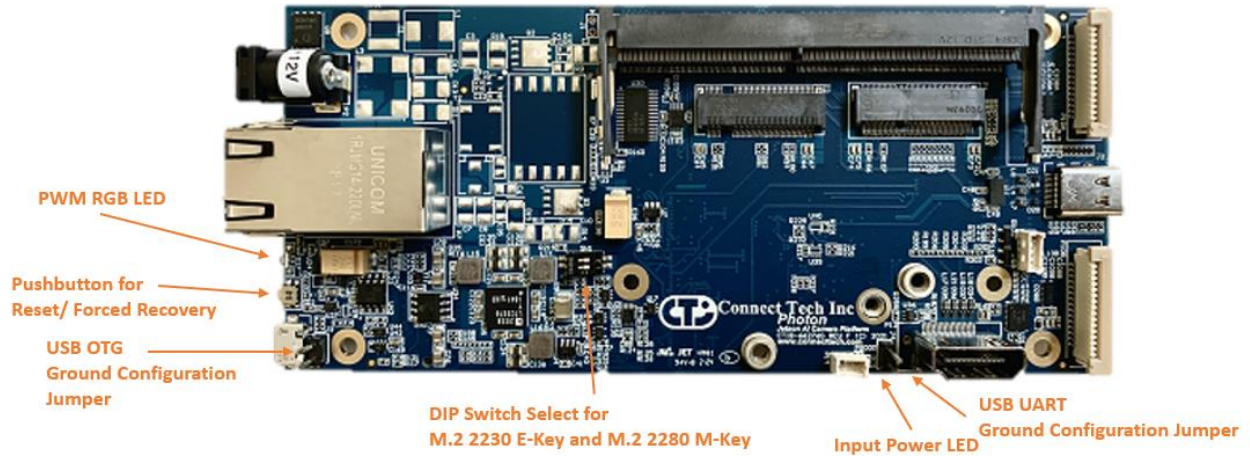

\*\*Revision F Board Shown above

Designator	Switch Description
SW1	DIP Switch Select for PCIe Lanes with M.2 2230 E-Key and M.2 2280 M-Key
SW2	Pushbutton for dual function Reset/Recovery

Designator	LED Description
D25	M.2 2280 M-Key Activity LED
D27	PWM RGB LED
D40	Input Power LED

Note: D40 Power Input LED is only available on Revision E and above

Designator	Jumper Description
J3**	P6 Micro-B USB UART Ground Configuration ON = System Frame GND and P6 Micro-B USB Shield Connected OFF = System Frame GND And P6 Micro-B USB Shield Disconnected
J4**	P13 Micro-B USB OTG Ground Configuration ON = System Frame GND and Digital Ground Connected OFF = 10Mohm resistance between System Frame GND and Digital GND

\*\*Note: J3 and J4 Shield GND Jumpers are only available on Revision F ONLY for NGX002 and NGX003. Also note that the configuration of J3:ON and J4:OFF will match the NGX002/NGX002 Revision A-E connectivity.

Note: Please refer to our Product Change Notice CTIU-00035(0.00) for more information on the Jumper Ground Configuration

## DETAILED FEATURE DESCRIPTION

### Jetson Module Connector

The NVIDIA® Jetson NX modules connect to the Photon AI Camera Platform via a TE Connectivity DDR4 SODIMM 260 Pin connector.

Function	Description
Location	P1
Type	TE Connectivity DDR4 SODIMM 260 Pin
Carrier Connector	Part Number: 2309413-1 Manufacturer: TE Connectivity
Mating Connector	Jetson NX Module
Pinout	Refer to NVIDIA® System-On-Module datasheet for pinout details for a specific module  <a href="https://developer.nvidia.com/embedded/downloads">https://developer.nvidia.com/embedded/downloads</a>
Board-to-Module Standoff Height	M2.5 x 6.57mm standoffs required between NVIDIA® Jetson NX Modules and Photon AI Camera Platform (CTI P/N: 155-0746-000.A)

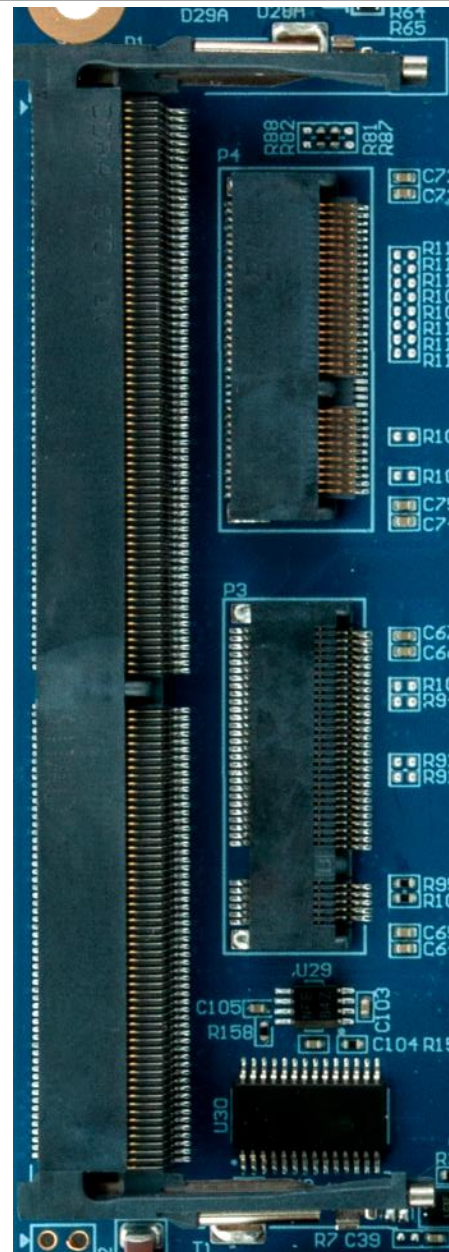

## USB 2.0 OTG/Host Mode Connector

The Photon AI Camera Platform implements a USB2.0 Micro-AB connector to allow host mode access to the module or OTG flashing of the module. Follow proper precautions when connecting any externally powered device onto the system as mentioned in the following [section](#)

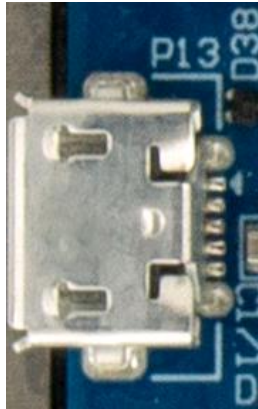
Function	Description	
Location	P13	
Type	Molex Micro-AB USB Connector	
Carrier Connector	Part Number: 0475890001 Manufacturer: Molex	
Mating Connector	USB 2.0 Micro-B or Micro-AB Cable	
Pinout	Refer to USB Standard	

**Note 1:** A USB Micro-B cable is required for OTG Flashing.

**Note 2:** A USB Micro-A cable is required for Host Mode.

## USB 2.0 FTDI Console Connector

The Photon AI Camera Platform implements a USB2.0 Micro-B connector to allow users console access to the module through an FTDI interface bridge (USB-Serial) to a desktop computer. Follow proper precautions when connecting any externally powered device onto the system as mentioned in the following [section](#)

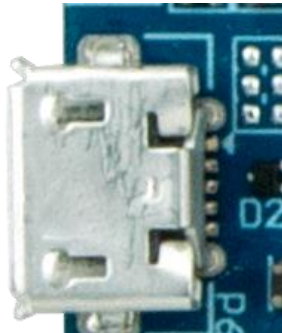
Function	Description	
Location	P6	
Type	TE Connectivity Micro-B USB Connector	
Carrier Connector	Part Number: 1981568-1 Manufacturer: TE Connectivity	
Mating Connector	USB 2.0 Micro-B Cable	
Pinout	Refer to USB Standard	

## HDMI Connector

The NVIDIA® Jetson NX modules will output video via the Photon AI Camera Platform vertical HDMI connector. Follow proper precautions when connecting any externally powered device onto the system as mentioned in the following [section](#)

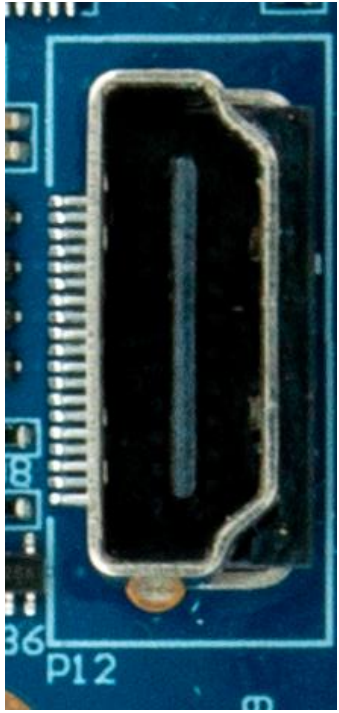
Function	Description	
Location	P12	
Type	Molex HDMI Vertical Connector	
Carrier Connector	Part Number: 0476591000 Manufacturer: Molex	
Mating Connector	HDMI Cable	
Pinout	Refer to HDMI Standard	

## 12V Barrel Jack Connector

The Photon AI Camera Platform has a 2.1mm, center positive Barrel Jack connector for +12V power supplies. Please ensure the Photon AI Camera Platform is powered with a DC source when required as mentioned in the following [section](#)

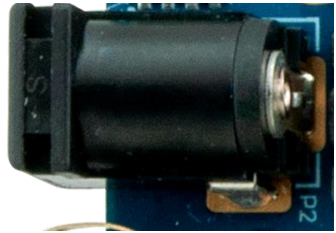
Function	Description	
Location	P2	
Type	CUI PJ-002A Barrel Jack Connector	
Carrier Connector	Part Number: PJ-002A Manufacturer: CUI	

## GBE RJ45 Ethernet & PoE PD Connector

The NVIDIA® Jetson NX modules will allow internet communication via the RJ-45 ethernet connector. GbE connector supports 10Mbps/ 100Mbps/ 1000Mbps.

The Photon AI Camera Platform can support Power over Ethernet delivery through this connector. As in all Power Over Ethernet implementations, the Photon AI Camera Platform includes power isolation transformers; therefore, it has an isolated ground from the power sourcing equipment. The Photon AI Camera Platform PoE PD version is typically used for remote installations where the only outside connectivity is the PoE PD connection itself.

Function	Description
Location	P7
Type	Pulse Electronics RJ-45 Ethernet Connector
Carrier Connector	Part Number: JXK0-0190NL Manufacturer: Pulse Electronics
Mating Connector	Ethernet (Cat5, Cat5e, Cat6, etc.) Cable
Pinout	Refer to Ethernet Standard

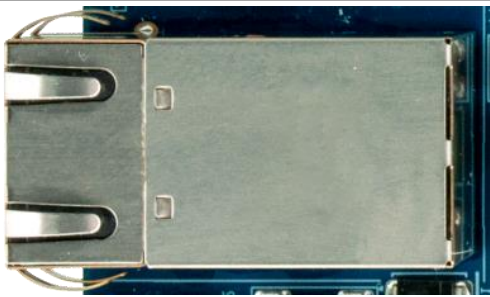

**Note 1:** PoE PD 802.3af / 802.3at supported on PoE PD version of the Photon AI Camera platform (CTI PN: NGX002)

**Note 2:** PoE PD is **not** supported on lower cost non-PoE PD of the Photon AI Camera platform (CTI PN: NGX003)



**WARNING:** If the Photon AI Camera Platform PoE PD version is powered over PoE in a lab setting or field service scenario, extreme care must be used when connecting externally powered equipment to P6 (USB), P9 (GPIO), P13 (USB) and P12 (HDMI) to avoid creating ground currents from differences in potential. Please refer to the following [section](#) for more information on connectivity.

## MIPI CSI-2 Connectors

The NVIDIA® Jetson NX modules will allow 2-Lane MIPI video input via the vertical FPC connectors. Please refer to our [Jetson Supported Cameras Page](#) for more information on our supported cameras.

Function	Description	
Location	P10A, P10B	
MIPI Lane usage	P10A – CSI0 P10B – CSI2	
Type	MOLEX FPC Vertical Connector 15 Pin	
Carrier Connector	Part Number: 0526101572 Manufacturer: MOLEX	
Pinout	Pin	Description
	1	GND
	2	CAM_DN0
	3	CAM_DP0
	4	GND
	5	CAM_DN1
	6	CAM_DP1
	7	GND
	8	CAM_CLKN
	9	CAM_CLKP
	10	GND
	11	CAM_PWDN
	12	CAM_MCLK
	13	I2C0_SCL
	14	I2C0_SDA
15	3.3V	

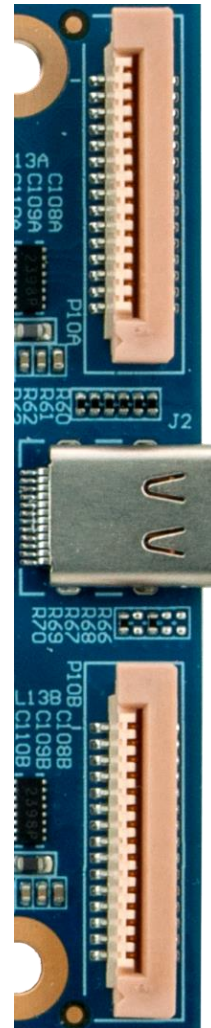

## M.2 B-Key Connector

The Photon AI Camera Platform implements an M.2 3042 B-Key for a Cellular Module. Please ensure you certify the wireless cellular module on your home network before using it on that network.

Function	Description
Location	P3
Type	JAE Electronics M.2 B-Key Connector
Carrier Connector	Part Number: SM3ZS067U310ABR1200 Manufacturer: JAE Electronics
Mating Connector	M.2 3042 Cellular Module
Pinout	Refer to M.2 NGFF Standard

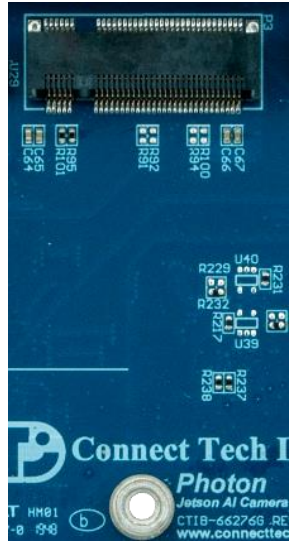

**Note:** Only a USB 2.0 based M.2 3042 B-Key Cellular module can be used with this connector. PCIe is not connected to the M.2 3042 B-Key.

## M.2 E-Key Connector

The Photon AI Camera Platform implements an M.2 2230 E-Key for a PCIe x1, USB 2.0 WiFi/Bluetooth Module.

Function	Description
Location	P4
Type	TE Connectivity M.2 E-Key Connector
Carrier Connector	Part Number: 2199119-4 Manufacturer: TE Connectivity
Mating Connector	M.2 2230 WiFi/Bluetooth Module
Pinout	Refer to M.2 NGFF Standard



## M.2 M-Key Connector

The Photon AI Camera Platform implements an M.2 2280 M-Key for a PCIe x4 NVMe.

Function	Description
Location	P5
Type	JAE Electronics M.2 M-Key Connector
Carrier Connector	Part Number: SM3ZS067U410AMR1000 Manufacturer: JAE Electronics
Mating Connector	M.2 2280 NVMe Module
Pinout	Refer to M.2 NGFF Standard

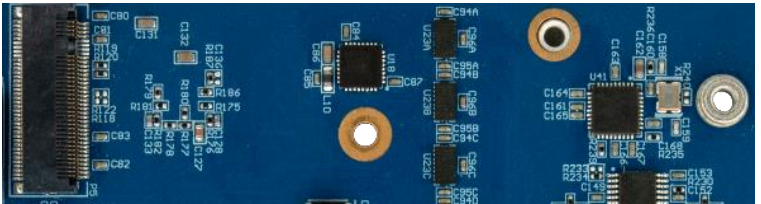

**Note 1:** Only PCIe based NVMe are compatible due to the hardware configuration. SATA based NVMe will not work.

**Note 2:** Revision G allows for both an NVMe and WiFi module at the same time.

## Dual microSD Card/ Module SIM Card Connector

The Photon AI Camera Platform implements a Dual microSD Card/SIM Card connector. Please ensure the microSD card used with the system is compatible with speed class supported on the Jetson Module used.

Function	Description
Location	P11
Type	Molex Dual microSD/SIM Card Connector
Carrier Connector	Part Number: 1042391430 Manufacturer: Molex
Mating Connector	microSD Card, SIM Card
Pinout	Refer to SD Card Standard and SIM Card Standard

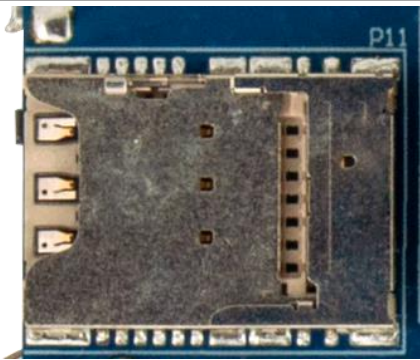

**Note:** microSD card is on the top, SIM card is on the bottom.

## 5V Fan Connector

The Photon AI Camera Platform implements a 4 Position Molex PicoBlade connector for active cooling capability.

Function		Description	
Location	P8		
Type	Molex 4 Position 1.25mm PicoBlade Connector		
Carrier Connector	Part Number: 53047-0410 Manufacturer: Molex		
Mating Connector	Molex 0510210400 PicoBlade Connector		
Pinout	Pin	Description	
	1	GND	
	2	+5V	
	3	FAN_TACH	
	4	FAN_PWM	

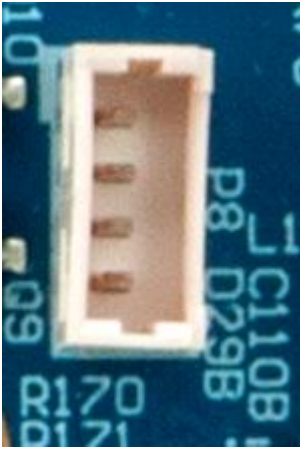

## RTC Battery Connector

The Photon AI Camera Platform implements a 3 Position Molex PicoBlade connector for an RTC Battery.

Function		Description	
Location	P14		
Type	Molex 3 Position 1.25mm PicoBlade Connector		
Carrier Connector	Part Number: 53047-0310 Manufacturer: Molex		
Mating Connector	Part Number: 0510210300 Manufacturer: Molex		
Pinout	Pin	Description	
	1	BAT+	
	2	NC	
	3	BAT-	



## I2C/GPIO/Power Connector

The Photon AI Camera Platform implements a JST SM09B Connector to allow for additional Power, GPIO, and I2C interfaces. Interface provides 3.3V capable i2C and GPIO. Follow proper precautions when connecting any externally powered device onto the system as mentioned in the following [section](#)

Function	Description	
Location	P9	
Type	JST 9 Position 1.0mm NSH Connector	
Carrier Connector	Part Number: SM09B-NSHSS-TB (LF)(SN) Manufacturer: JST	
Mating Connector	JST NSHR-09V-S NSH Connector	
Pinout	Pin	Description
	1	+3.3V
	2	GND
	3	CAM_GPIO0 / GPIO0
	4	CAM_GPIO1 / GPIO1
	5	CAM_GPIO2 / GPIO2
	6	CAM_GPIO3 / GPIO3
	7	Not Connected
	8	CAM_I2C_SCL
9	CAM_I2C_SDA	
Notes	I2C can appear under a different bus for different Jetson modules: Nano™ uses I2C bus i2c-9 Xavier™ NX uses I2C bus i2c-11 TX2™ NX uses I2C bus i2c-11 For more information on I2C usage, please click <a href="#">here</a> .  GPIO SYSFS for GPIO0, GPIO1, GPIO1, GPIO3 for different Jetson modules are respectively: Nano™ uses SYSFS 504, 505, 506, 507 Xavier™ NX uses SYSFS 232,233,234,235 TX2™ NX uses SYSFS 248,249,250,251 For more information on GPIO usage, please click <a href="#">here</a>	

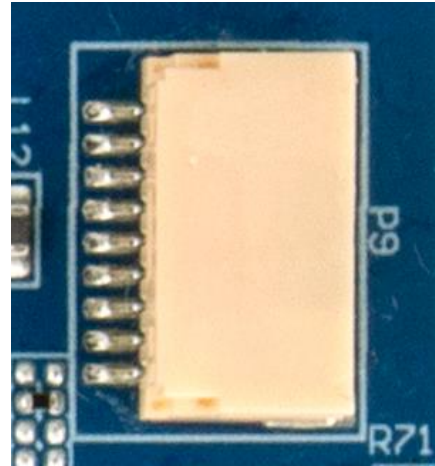

## Reset & Recovery Pushbutton

The Photon AI Camera Platform implements a dual functionality pushbutton for both Reset and Recovery of the platform. To Reset the module, simply press and hold the pushbutton for a minimum of 250 milliseconds. To put the Jetson module into Force Recovery mode, press and hold the pushbutton for a minimum of 10 seconds.

Function	Description	
Location	SW2	
Type	Panasonic EVQP7 Pushbutton	
Carrier Connector	Part Number: EVQ-P7A01P Manufacturer: Panasonic	
Reset Button Press	Minimum 250ms (typ.)	
Recovery Button Press	Minimum 10s (typ.)	

**Note:** A full power cycle of the Photon AI Camera Platform must be performed after module flashing.

## M.2 M-Key / M.2 E-Key DIP Switch Selection

The Photon AI Camera Platform implements a 2 position DIP switch for the selection of the M.2 2280 M-Key (NVMe) or the M.2 2230 E-Key (WiFi/Bluetooth).

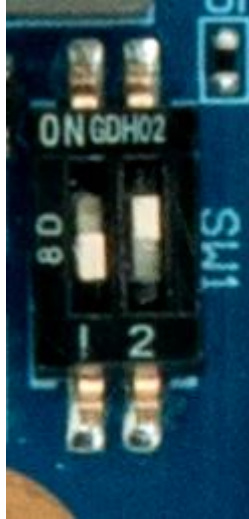
Function	Description	
Location	SW1	
Type	TE Connectivity 1571983-1 DIP Switch	
Carrier Connector	Part Number: 1571983-1 Manufacturer: TE Connectivity	
SW1-1	Manufacturing use ONLY. Leave in OFF position for proper operation.	
SW1-2	Nano™ ON: M-Key Only (NVMe) Nano™ OFF: E-Key Only (Wifi/BT)  Xavier™ NX ON: M-Key + E-Key Xavier™ NX OFF: E-Key Only	

## PWM RGB LED

The Photon AI Camera Platform implements a RGB LED that can be controlled by the user.

Function	Description	
Location	D27	
Type	RGB LED	
Carrier Connector	Part Number: LTST-S310F2KT Manufacturer: Lite-On	

## USB 3.0 Type-C Connector

The Photon AI Camera Platform allows for USB throughput and speed based on the limitations of the Jetson module used. The NVIDIA® Jetson modules will allow camera input via the USB 3.0 Type-C connector.

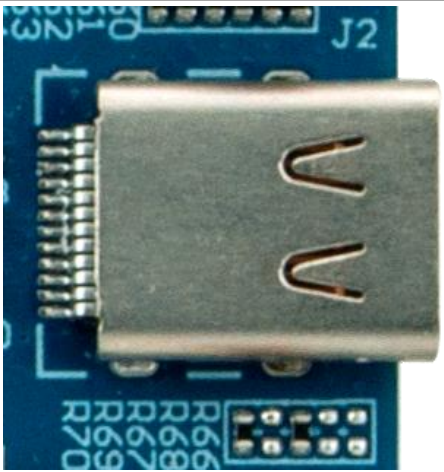
Function	Description	
Location	J2	
Type	Wurth Electronics USB3.0 Type-C Connector	
Carrier Connector	Part Number: 632723300011 Manufacturer: Wurth Electronics	
Mating Connector	USB Type-C Cable	
Pinout	Refer to USB3.0 Type-C Pinout	

**Note 1:** This port can be used for host mode access to the NVIDIA® Jetson Nano™ module at 5Gbps only.

**Note 2:** Display devices or devices requiring 20V power modes are not supported.

## INSTALLATION

1. **Ensure all external system power supplies are off and disconnected. Please refer to the [section](#) below on installation and advised cautions when using PoE PD**
2. **Install the NVIDIA® Jetson NX Module into the DDR4 260 Pin SODIMM Connector (P1).**

Be sure to follow the manufacturer's directions for proper installation of mounting hardware, thermal solution, and any other applicable requirements from the manufacturer.
3. **The switches and jumpers should be set correctly before power up. Please refer to the [LEDs, Jumpers, and Switch summary](#) on more information on configuration.**
4. **Install the necessary cables for your application. At a minimum these would include:**
  - a) **Power cable to the input power connector or ethernet cable into its port**
  - b) **HDMI video display cable or Micro-B cable into the Console USB Port**
  - c) **Keyboard and Mouse via USB (a hub may be required for multiple devices)**
  - d) **MIPI Camera(s) or USB3 Type-C Camera (if applicable)**
  - e) **M.2 2280 M-Key or M.2 2230 E-Key Module (if applicable)**
  - f) **M.2 3042 B-Key Module (if applicable)**
5. **Connect the Power Cable of the +12V Power Supply into the Barrel Jack or Power Over Ethernet capable switch to the Ethernet Port (NGX002 Only).**
6. **Plug the AC cable on the +12V Power Supply into the wall socket (this does not apply to Power Over Ethernet). DO NOT power up your system by plugging in live power.**

## POE PD AND GROUNDING DURING HOT PLUG EVENTS

When powering the NGX002 through Power-over-Ethernet (PoE), the system or digital ground is created through an isolation transformer and has a floating ground point. This means there is a chance for the Photon's digital ground to be at a higher potential voltage than the externally powered devices ground reference. If an externally powered peripheral is plugged in while the Photon is live (hot-plugged) then the two ground points will try to equalize, with potential for a large ground current to be produced. This type of ground current event has the risk to cause damage to the connected peripherals or the interface connections of the Photon NGX002.

**Note** that this applies only in the event of required hot plugging of the following interfaces: **USB (P6, P13, J2), GPIO (P9) and HDMI (P12)**

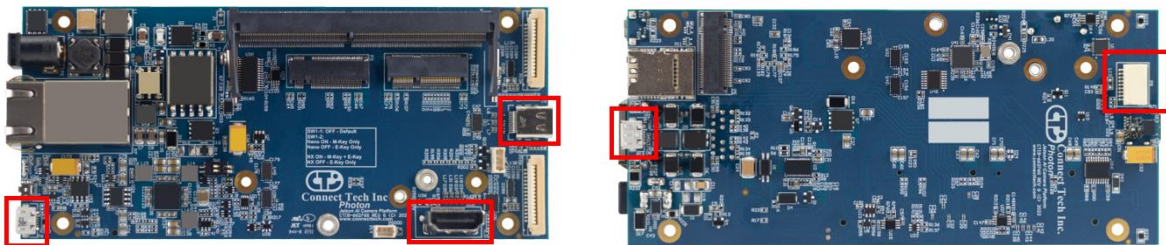

If any of the above interfaces need to be hot plugged either within product operation or during installation/configuration, precautions must be taken and one of the following methods followed.

### 1. Plug in all Externally Powered Equipment First

Plug in and power all externally powered devices before applying power to the NGX002 via PoE (ethernet), connecting this as the last step. The common digital grounds between the interfaces will pull the ground reference of the Photon to the same potential before the unit has the chance to be powered. With Photons ground referenced to the externally powered devices ground, the opportunity of a ground current event should be eliminated.

### 2. Switch Power Input to DC Barrel Jack

If your application required the hot plugging of the USB, GPIO or HDMI interfaces, moving from PoE PD to barrel Jack DC barrel jack input will create a ground reference from the DC source that will likely mimic that of other powered equipment around it. (Photon, PC and Monitor all powered from same AC Power ground)

### 3. Use Peripheral Isolators

Another option when field service is required is to use HDMI and USB signal isolators.

#### 4. Create a System/Earth Ground Reference

If the above options are not suitable for your particular application, then the Photon should have its Frame Ground connected to a System or earth ground (eg, AC power ground, similar to that of the equipment being plugged in). The Frame ground connects to digital ground through a 10M resistor. Connecting this will bring the digital ground potential closer to the externally powered devices. For information on Frame ground locations see grounding notes below.

Note: Rev F added an option to short the resistor out. It has been removed in Rev G

Note: Rev G, with default connections, if user chassis is metallic and contacting any of the peripheral shells, the resistor will be shorted.

## GROUNDING NOTES

There are several resistors populated on the Photon that can be populated or depopulated to meet users grounding requirements. Please note that board level modification will void product warranty, if a particular grounding connection scheme will be required, please contact [Connect Tech Support](#) to discuss available options.

### Mounting Holes

**Revision A-F:** The four (4) mounting holes are electrically isolated

**Revision G:** The mounting holes are connected to Frame GND through OR resistors.

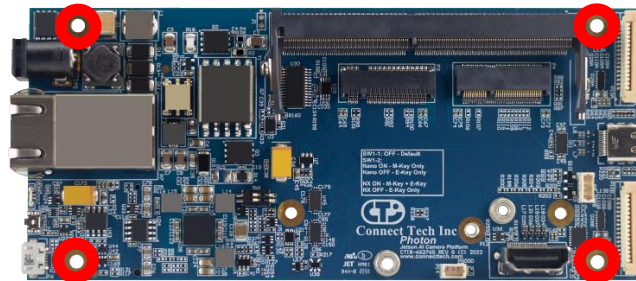

### Connectors Shells

Connector	Description	Rev A-F Shell Default State	Rev G Shell Default State
J2	USB Type C	Frame GND	Digital GND
P6	USB Debug UART	Frame GND Note: Rev F added an option to No Connect the shell	Digital GND
P7	RJ45	Frame GND	Frame GND
P11	SD Card	Frame GND	Digital GND
P12	HDMI	Frame GND	Digital GND
P13	USB OTG	Frame GND	Digital GND

Revision G connects the shells to digital ground by default. However, options exist for these to connect to frame ground or float depending on the required setup.

Please contact for [Connect Tech Support](#) for further information. Or if a preconfigured grounding method is required, contact [sales@connecttech.com](mailto:sales@connecttech.com).

## SOFTWARE SETUP

Prior to hardware installation, ensure the correct software installed on the Jetson Module.

Supported Software Board Support Packages can be found on our website:

<https://connecttech.com/resource-center/l4t-board-support-packages/>

Board Support Package Installation instructions can be found:

<http://connecttech.com/resource-center/kdb373/>

SDK Component Installation instructions can be found:

<http://connecttech.com/resource-center/kdb374/>

For all other Jetson documentation, please check out our Resource Center:

<https://connecttech.com/resource-center-category/all-kdb-entries/>

If you would like to switch between Photon Board Support Package configurations without reflashing your system, run the following command as a root user when using a Xavier™ NX module:

```
sudo cti-nx-fdt.sh
```

or when using a Nano™ module:

```
sudo cti-nano-fdt.sh
```

## OPTIONAL INTEGRATION FEATURES

Feature	Module Size	Connector	Manufacturer
Cellular Module	M.2 3042	P3	Quectel
WiFi / BT	M.2 2230	P4	Intel
NVMe	M.2 2280	P5	Samsung

## POWER CONSUMPTION & THERMALS

### Thermal Details

The Photon AI Camera Platform has an operating temperature range of -25°C to +85°C. However, it is important to note that the NVIDIA® Jetson Modules have their own properties separate to that of the Photon AI Camera Board. The NVIDIA® Jetson modules match the Photon operating temperature range of -25°C to +85°C (-13°F to +185°F).

Customer responsibility requires proper implementation of a thermal solution that maintains the NVIDIA® Jetson modules SoC and Thermal Transfer Plate (TTP) temperatures below the specified temperatures (shown in the tables below) under the maximum thermal load and system conditions for their use case.

#### NVIDIA® Jetson Nano™

Parameter	Value	Units
Maximum Tegra X1 Operating Temperature	T.cpu = 97	°C
	T.gpu = 97.5	°C
Tegra X1 Shutdown Temperature	T.cpu = 103	°C
	T.gpu = 104	°C

#### NVIDIA® Jetson Xavier™ NX

Parameter	Value	Units
Maximum Xavier™ NX SoC Operating Temperature	T.cpu = 90.5	°C
	T.gpu = 91.5	°C
	T.aux = 90.0	°C
Xavier™ NX SoC Shutdown Temperature	T.cpu = 96.0	°C
	T.gpu = 97.0	°C
	T.aux = 95.5	°C



#### NVIDIA® Jetson TX2™ NX

Parameter	Value	Units
Maximum Tegra X2 Operating Temperature	T.cpu = 95.5	°C
	T.gpu = 95.5	°C
Tegra X2 Shutdown Temperature	T.cpu = 101	°C
	T.gpu = 101	°C

## Connect Tech Custom Thermal Solutions

Connect Tech Inc. has three custom solutions available for customer implementation, namely, an Active Cooling Solution, Passive Cooling Solution, and Thermal Transfer Plate Solution. Please contact Connect Tech Inc. for more information regarding these options.

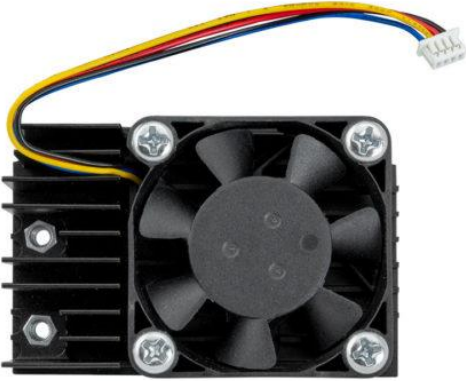
### Connect Tech Inc. NVIDIA® Jetson Nano™ Thermal Solutions

Function	Part Number	
Active Cooling	XHG309	
Passive Cooling	XHG308	
Thermal Transfer Plate Cooling	XHG310	

**Connect Tech Inc. NVIDIA® Jetson Xavier™ NX Thermal Solutions**

Function	Part Number	
Active Cooling Cools SoC and Memory	XHG312	
Active Cooling Cools SoC Only Note: Needs additional fan extension cable	XHG314	
Passive Cooling	XHG311	
Thermal Transfer Plate Cooling	XHG313	

## CURRENT CONSUMPTION DETAILS

Parameter	Value	Units	Temperature
NVIDIA® Jetson Nano™ Module, Passive Cooling, Idle, HDMI, Ethernet, Mouse and Keyboard plugged in	3.5	W	25°C (typ.)
NVIDIA® Jetson Nano™ Module, Passive Cooling, MAXN mode, CPU stressed, GPU stressed, HDMI, Ethernet, Mouse and Keyboard plugged in	13.5	W	25°C (typ.)

Parameter	Value	Units	Temperature
NVIDIA® Jetson Xavier™ NX Module, Passive Cooling, Idle, HDMI, Ethernet, Mouse and Keyboard plugged in	7.5	W	25°C (typ.)
NVIDIA® Jetson Xavier™ NX Module, Passive Cooling, 15W - 6 core mode, CPU stressed, GPU stressed, HDMI, Ethernet, Mouse and Keyboard plugged in	29	W	25°C (typ.)