

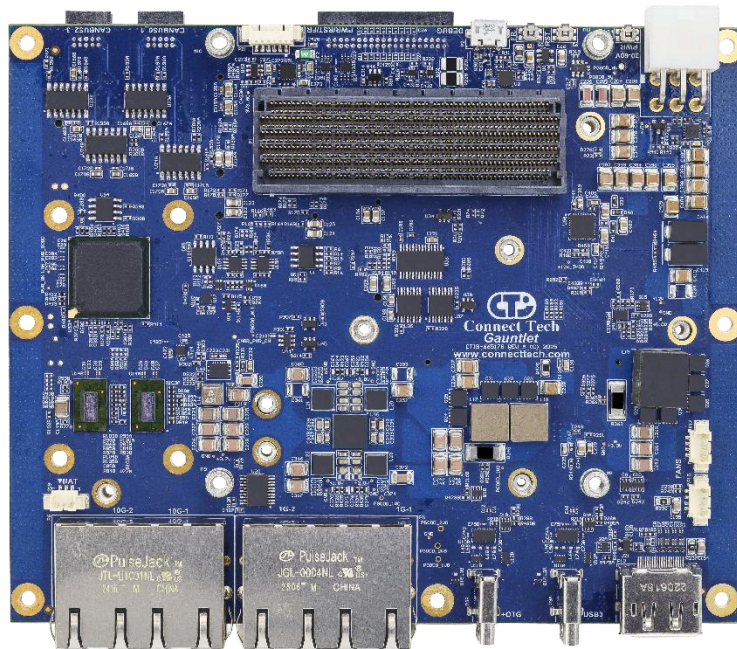

**Connect Tech Inc.**  
Embedded Computing Experts

# USERS GUIDE



## Gauntlet Carrier for NVIDIA® Jetson Thor™ T5000

CTIM-00140 Revision 0.06 2026-03-31



**CONNECT TECH**  
connecttech.com  
sales@connecttech.com

# TABLE OF CONTENTS

<b>Table of Contents .....</b>	<b>2</b>
<b>Preface .....</b>	<b>3</b>
Disclaimer .....	3
Customer Support Overview .....	3
Contact Information .....	3
Limited Product Warranty .....	4
Copyright Notice .....	4
Trademark Acknowledgment .....	4
ESD Warning .....	5
<b>Revision History .....</b>	<b>5</b>
<b>Introduction .....</b>	<b>6</b>
Product Features and Specifications .....	6
Part Numbers / Ordering Information .....	7
<b>Product Overview .....</b>	<b>8</b>
Block Diagram .....	8
Connector Summary & Locations .....	9
Dip Switch Summary & Locations .....	11
<b>Detailed Feature Description .....</b>	<b>12</b>
Power Connector .....	12
Jetson Thor™ Board-to-Board Carrier Connector .....	12
10G Ethernet (2 Ports) .....	13
1G Ethernet (2 Ports) .....	13
USB 3.2 (2 Ports) .....	14
DISPLAYPORT Video Output .....	14
RTC Battery Connector .....	15
Fan Connectors .....	15
M.2 M-Key 2280 expansion slots .....	16
M.2 B-Key 3042/3052 expansion slot .....	16
M.2 E-Key 2230 expansion slot .....	17
External Power/Reset/Force Recovery Connector .....	17
CAMERA Expansion Connector .....	18
GPIO/SPI/I2C/UART Connector .....	20
CAN BUS Connectors .....	22
<b>Typical Installation .....</b>	<b>23</b>
<b>Force Recovery Mode .....</b>	<b>23</b>
<b>Power Consumption &amp; Thermals .....</b>	<b>24</b>
<b>Weight .....</b>	<b>25</b>
<b>Cables .....</b>	<b>26</b>

## PREFACE

### Disclaimer

The information contained within this user’s guide, including but not limited to any product specification, is subject to change without notice.

Connect Tech assumes no liability for any damages incurred directly or indirectly from any technical or typographical errors or omissions contained herein or for discrepancies between the product and the user’s guide.

### Customer Support Overview

If you experience difficulties after reading the manual and/or using the product, contact the Connect Tech reseller from which you purchased the product. In most cases the reseller can help you with product installation and difficulties.

In the event that the reseller is unable to resolve your problem, our highly qualified support staff can assist you. Our support section is available 24 hours a day, 7 days a week on our website at: <http://connecttech.com/support/resource-center/>. See the contact information section below for more information on how to contact us directly. Our technical support is always free.

### Contact Information

Contact Information	
<b>Mail/Courier</b>	Connect Tech Inc. Technical Support 489 Clair Rd. W. Guelph, Ontario Canada N1L 0H7
<b>Contact Information</b>	<a href="mailto:sales@connecttech.com">sales@connecttech.com</a> <a href="http://connecttech.com">connecttech.com</a>  Toll Free: 800-426-8979 (North America only) Telephone: +1-519-836-1291 Facsimile: 519-836-4878 (on-line 24 hours)
<b>Support</b>	Please go to the <a href="#">Connect Tech Resource Center</a> for product manuals, installation guides, device drivers, BSPs and technical tips.  Submit your <a href="#">technical support questions</a> to our support engineers. Technical Support representatives are available Monday through Friday, from 8:30 a.m. to 5:00 p.m. Eastern Standard Time.

## Limited Product Warranty

Connect Tech Inc. provides a 1-year Warranty for this product. Should this product, in Connect Tech Inc.'s opinion, fail to be in good working order during the warranty period, Connect Tech Inc. will, at its option, repair or replace this product at no charge, provided that the product has not been subjected to abuse, misuse, accident, disaster or non-Connect Tech Inc. authorized modification or repair.

You may obtain warranty service by delivering this product to an authorized Connect Tech Inc. business partner or to Connect Tech Inc. along with proof of purchase. Product returned to Connect Tech Inc. must be pre-authorized by Connect Tech Inc. with an RMA (Return Material Authorization) number marked on the outside of the package and sent prepaid, insured and packaged for safe shipment. Connect Tech Inc. will return this product by prepaid ground shipment service.

The Connect Tech Inc. Limited Warranty is only valid over the serviceable life of the product. This is defined as the period during which all components are available. Should the product prove to be irreparable, Connect Tech Inc. reserves the right to substitute an equivalent product if available or to retract the Warranty if no replacement is available.

The above warranty is the only warranty authorized by Connect Tech Inc. Under no circumstances will Connect Tech Inc. be liable in any way for any damages, including any lost profits, lost savings or other incidental or consequential damages arising out of the use of, or inability to use, such product.

## Copyright Notice

The information contained in this document is subject to change without notice. Connect Tech Inc. shall not be liable for errors contained herein or for incidental consequential damages in connection with the furnishing, performance, or use of this material. This document contains proprietary information that is protected by copyright. All rights are reserved. No part of this document may be photocopied, reproduced, or translated to another language without the prior written consent of Connect Tech, Inc.

Copyright © 2026 by Connect Tech, Inc.

## Trademark Acknowledgment

Connect Tech, Inc. acknowledges all trademarks, registered trademarks and/or copyrights referred to in this document as the property of their respective owners. Not listing all possible trademarks or copyright acknowledgments does not constitute a lack of acknowledgment to the rightful owners of the trademarks and copyrights mentioned in this document.

## ESD Warning



Electronic components and circuits are sensitive to ElectroStatic Discharge (ESD). When handling any circuit board assemblies including Connect Tech COM Express carrier assemblies, it is recommended that ESD safety precautions be observed. ESD safe best practices include, but are not limited to:

- Leaving circuit boards in their antistatic packaging until they are ready to be installed.
- Using a grounded wrist strap when handling circuit boards, at a minimum you should touch a grounded metal object to dissipate any static charge that may be present on you.
- Only handling circuit boards in ESD safe areas, which may include ESD floor and table mats, wrist strap stations and ESD safe lab coats.
- Avoiding handling circuit boards in carpeted areas.
- Try to handle the board by the edges, avoiding contact with components.

## REVISION HISTORY

Revision	Date	Changes
0.00	2025-06-13	Preliminary Release
0.01	2025-09-19	Updated input voltage range, ethernet port labelling, IO connector pinout and IO SW cross reference
0.02	2025-10-24	Updated input voltage range, system power info, weight, and updated specification notes
0.03	2025-11-26	Added external PWR/FR/RST connector pinout and thermal information
0.04	2026-02-18	Updated Branding
0.05	2026-03-12	Updated Thor™ references to specify Thor™ T5000, updated idle power scenario, added passive heatsink information
0.06	2026-03-31	Updated cable information

## INTRODUCTION

Gauntlet is a full featured carrier board specifically designed for commercially deployable platforms.

Gauntlet provides access to the impressive array of latest generation interfaces available on the NVIDIA® Jetson Thor™ T5000 including dual 10GBASE-T Ethernet. The Gauntlet also includes 2x USB 3.2, 2x GbE, Display Port, 2x NVMe storage slots, 1x WiFi/BT expansion and a cell modem expansion slot. As well as several GPIO/SPI/I2C/UART/RS232-485/CAN interfaces and a locking 6pin Mini-Fit Jr. Power input Connector.

### Product Features and Specifications

Specifications	
<b>Compatibility</b>	NVIDIA® Jetson Thor™ T5000 128GB
<b>Networking</b>	2x 10GBASE-T, 2x 1GBASE-T
<b>Camera Inputs</b>	1x 16-Lane MIPI Expansion Connector that interfaces directly to a range of MIPI CSI, GMSL2 or FPD-Link III image sensors.
<b>Storage</b>	2x M.2 Key M 2280 for NVMe (1x PCIe Gen 4 x4 and 1x PCIe Gen 4 x2)
<b>UARTs</b>	2x @ 3.3V levels UART_A and UART_B 2x RS-232/RS-485 (full duplex) UART
<b>CAN</b>	4x CAN 2.0b Non-Isolated Ports
<b>Expansion Slots</b>	1x M.2 Key E 2230 Wifi/BT (PCIe/USB2) 1x M.2 Key B 3042/3052 (LTE/5G - USB3) with Nano SIM (4FF)
<b>Display</b>	1x DisplayPort (DP++ capable using an HDMI adapter)
<b>USB</b>	1x USB 3.2 Gen 2 Port (Type-C) 1x USB 3.2 Gen 2 Port (Type-C, Dual-Role-Data capable)
<b>I2C/SPI</b>	2x I2C Bus @ 3.3V IO 2x SPI Bus @ 3.3V IO
<b>GPIO</b>	4x 3.3V GPI Inputs 6x 3.3V GPO Outputs (2xPWM Capable) 1x 3.3V Power Pin at 1A
<b>Input Power</b>	36 – 60V DC Wide input Power connector (6pin Mini-fit Jr)
<b>Operating temperature</b>	Carrier Only: -40°C to +85°C (Note 1)
<b>Dimensions</b>	155 x 126mm

**Note 1:** Thor™ T5000 module operating temperature is from -25°C to a maximum TTP temperature of 80°C

## Part Numbers / Ordering Information

Part Number	
AGX301	Carrier Only
AGX301-xxx	Pre-Integrated Products – ask <a href="mailto:sales@connecttech.com">sales@connecttech.com</a> for more options
MSG121	AC/DC Development PSU 6pin 48V 360W
CBG630	12” Misc I/O breakout cable with flying leads (included)
CBG631	12” CAN Bus breakout cable with flying leads (included)
CBG632	12” 6 pin to 6 pin Mini-Fit Jr power cable (included)

# PRODUCT OVERVIEW

## Block Diagram

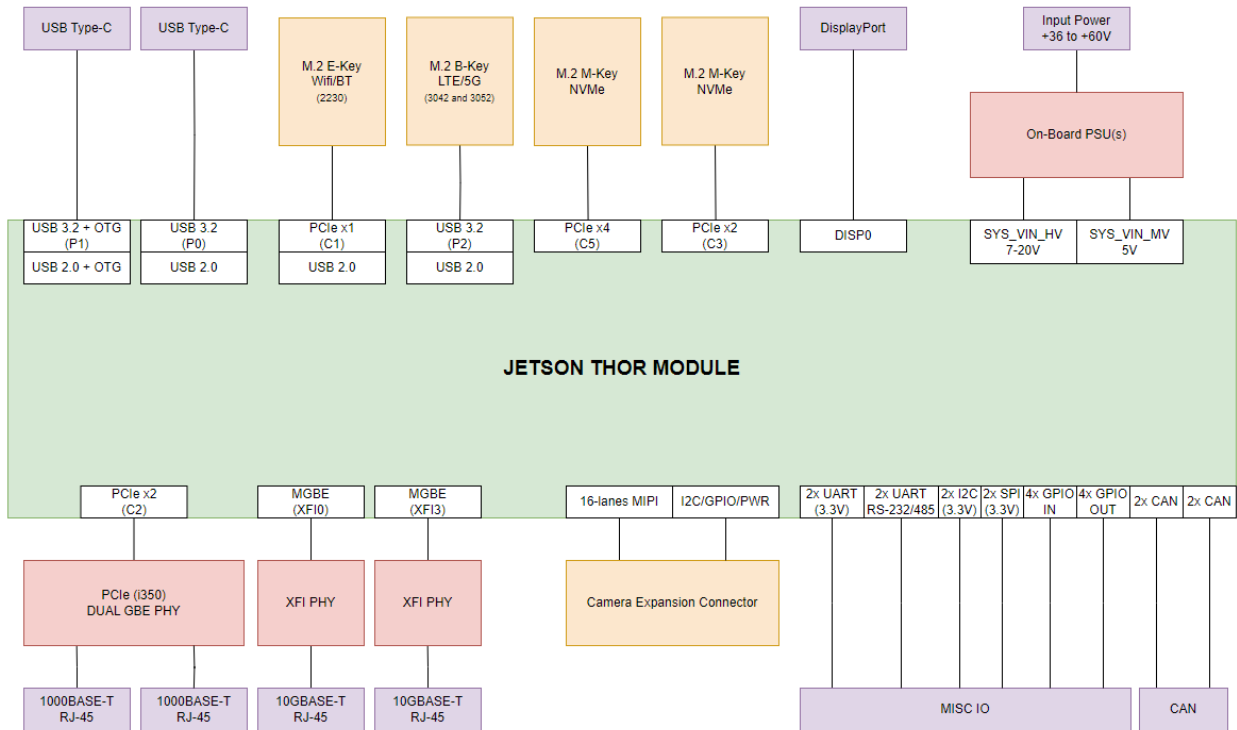

## Connector Summary & Locations

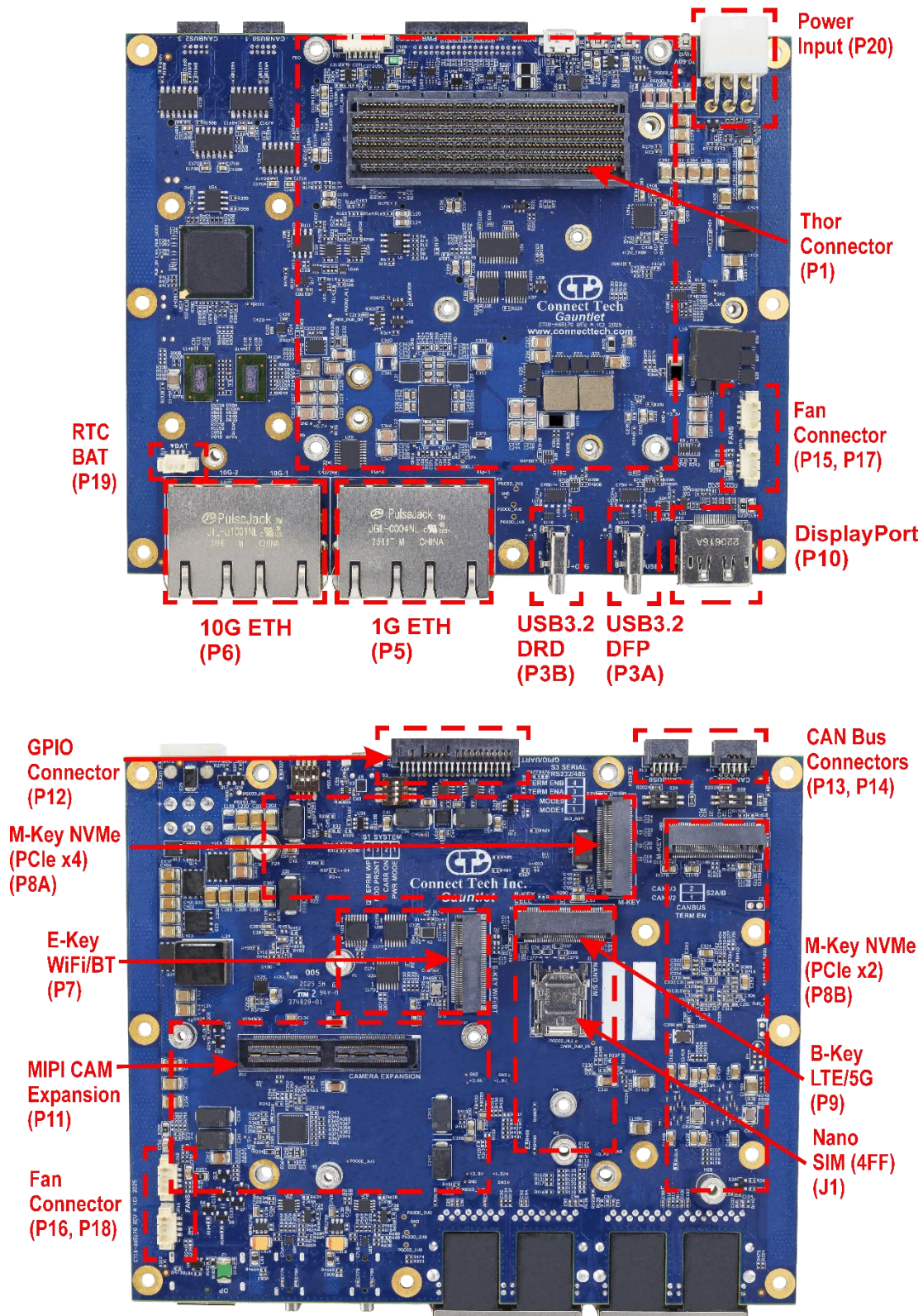

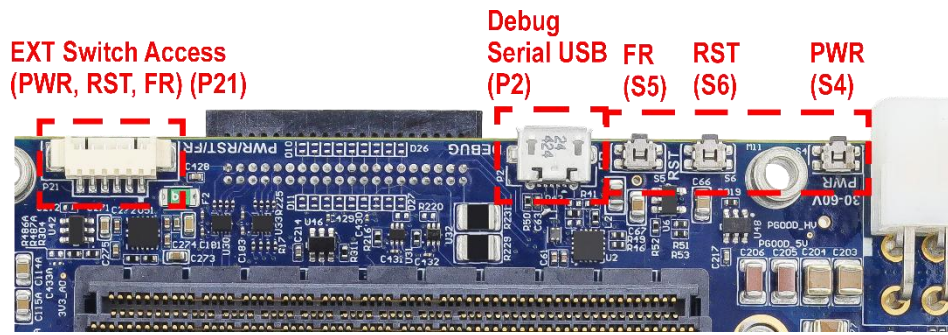

Designator	Description
P1	Jetson Thor™ connector
P2	USB UART Debug Console connector
P3A	USB 3.2 device port
P3B	USB 3.2 device port and Dual-Role-Data (DRD) programming port connector
P5	Dual GbE RJ45 connector
P6	Dual 10G RJ45 connector
P7	M.2 E-Key connector (2230)
P8A, P8B	M.2 M-Key (NVMe) connector
P9	M.2 B-Key connector (3042 and 3052)
P10	DisplayPort Connector (DP++ HDMI dongle compatible)
P11	MIPI Camera Expansion connector
P12	GPIO/SPI/I2C/UART/RS232-485
P13	CAN Bus 0/1 Connector
P14	CAN Bus 2/3 Connector
P15, P16	12V Fan connector (Primary – includes TACH feedback)
P17, P18	12V Fan connectors auxillary (no TACH feedback – see primary connector)
P19	RTC Battery connector
P20	6-pin Mini-Fit Jr Power Connector
P21	PWR, RST and Force Recovery external cable attach
J1	Nano SIM top loading connector (4FF)
S4	Power Button (used for manual power mode)
S5	Force Recovery Button (used to put module into flash mode)
S6	Reset Button (used to reset the system at any time)

## Dip Switch Summary & Locations

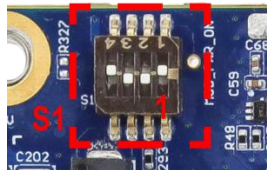
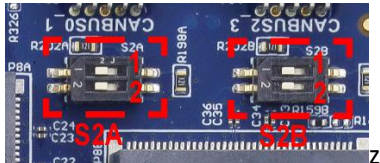
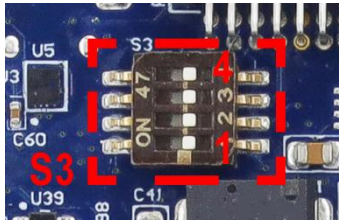
Designator	Description																				
S1	<p><i>Power Selection and MFG settings Dip Switch</i></p> <p>1 – <b>POWER ON Mode Selection Auto ON = OFF, Manual = ON</b>                      2 – *Used for Manufacturing test only*                      3 – *Used for Manufacturing test only*                      4 – *Used for Manufacturing test only*</p> 																				
S2A, S2B	<p>CANBus Termination Enable”</p> <p>1 – 120ohm Termination Enable Channel 0 (S2A) and Channel 2 (S2B)                      2 – 120ohm Termination Enable Channel 1 (S2A) and Channel 3 (S2B)</p> 																				
S3	<p>RS232/RS485 Serial Port Mode and Termination Selection:</p> <p>1 – MODE0                      2 – MODE1                      3 – RS485 RX Termination Enable for Channel A                      4 – RS485 RX Termination Enable for Channel B</p> <table border="1" style="width: 100%; border-collapse: collapse; text-align: center;"> <thead> <tr style="background-color: #cccccc;"> <th>MODE0 (1)</th> <th>MODE1 (2)</th> <th>Channel A</th> <th>Channel B</th> </tr> </thead> <tbody> <tr> <td>OFF</td> <td>OFF</td> <td>OFF</td> <td>OFF</td> </tr> <tr> <td>ON</td> <td>ON</td> <td>RS-232</td> <td>RS-232</td> </tr> <tr> <td>ON</td> <td>OFF</td> <td>N/A</td> <td>N/A</td> </tr> <tr> <td>OFF</td> <td>ON</td> <td>RS-485</td> <td>RS-485</td> </tr> </tbody> </table> 	MODE0 (1)	MODE1 (2)	Channel A	Channel B	OFF	OFF	OFF	OFF	ON	ON	RS-232	RS-232	ON	OFF	N/A	N/A	OFF	ON	RS-485	RS-485
MODE0 (1)	MODE1 (2)	Channel A	Channel B																		
OFF	OFF	OFF	OFF																		
ON	ON	RS-232	RS-232																		
ON	OFF	N/A	N/A																		
OFF	ON	RS-485	RS-485																		

## DETAILED FEATURE DESCRIPTION

### Power Connector

Power Input: 36 – 60V input range (recommended: 48V / 360W)

Function	Gauntlet Power Supply Connector	
Location	P20	
Type	Mini Fit Jr 2x3 Right Angled	
Connector	Part Number: 39301061 Manufacturer: Molex	
Mating Connector	CBG632 Receptacle Housing 5557 series Cable Assembly 45135 series	
Pinout	Pin 1-3 are Power Input (VIN) 36 – 60V Pin 4-6 are Ground (GND)	

### Jetson Thor™ Board-to-Board Carrier Connector

With the NVIDIA® Jetson Thor™, the processor and chipset are implemented on the module.

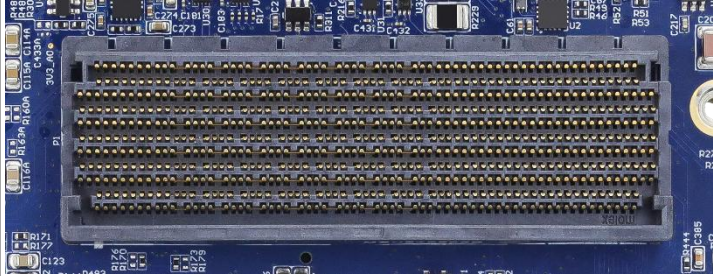
Function	NVIDIA® Jetson Thor™ Module Interface	
Location	P1	
Type	Molex Mirror Mezz™ Connector	
Connector	Part Number: 203456-0003 Manufacturer: Molex	
Mating Connector	Same as above.	
Pinout	Refer to NVIDIA Jetson Thor™ System-on-Module datasheet and OEM design guide for pinout details	

## 10G Ethernet (2 Ports)

Two ports of RJ45 10G BASE-T Ethernet for high-speed networking.

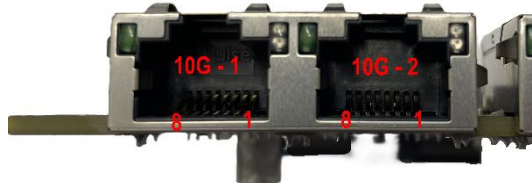
Function	10 GBE Network Connectivity	
Location	P6	
Type	2x 8 pin RJ45 with integrated Magnetics	
Connector	Manufacturer: Pulse	
Mating Cable	Standard RJ45 CAT 6a	
Pinout	As per the IEEE-802.3 specification	
Notes	Both channels go through AQR113 PHYs originating from MGBE0 and MGBE3 on the Thor™ T5000 Module.	

## 1G Ethernet (2 Ports)

Two ports of RJ45 1G BASE-T Ethernet for networking.

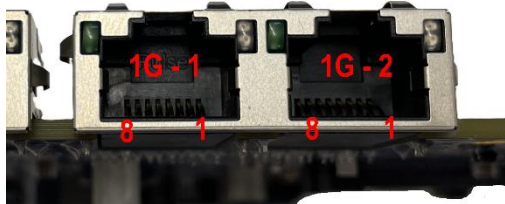
Function	GBE Network Connectivity	
Location	P5	
Type	2x 8 pin RJ45 with integrated Magnetics	
Connector	Manufacturer: Pulse	
Mating Cable	Standard RJ45 CAT 5e or better	
Pinout	As per the IEEE-802.3 specification	
Notes	Both channels go through the PCIe ethernet controller (Intel i350 or equivalent)	

## USB 3.2 (2 Ports)

Two ports of USB 3.2 Type-C interfaces with 3A at 5V output capable per port.

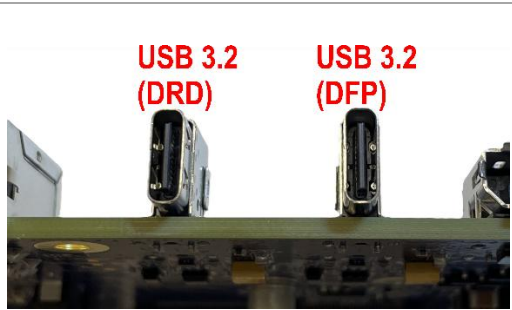
Function	USB 3.2 General Purpose Ports	
Location	P3A, P3B	
Type	2x 26 pin Type C USB Connectors	
Connector	Part Number: USB4200-03-A Manufacturer: GCT	
Mating Cable	Standard USB 3.0 Type C or better	
Pinout	As per the USB 3.2 specification	
Notes	One USB port is only a DFP (Downward facing port), the second is capable of both DFP and UFP (Upward Facing Port). The DRD port (P3B) is used for module Flashing access in recovery mode. Each USB port is capable of delivering up to 3A at 5V at USB 3.2 Gen 2 (10Gbps) speeds for both ports. Note that alternate modes for power or video are NOT supported on these USB interfaces. USB devices only.	

## DISPLAYPORT Video Output

The Gauntlet supports one DISPLAYPORT capable of 4k output resolution.

Function	Display Output	
Location	P10	
Type	Full size DisplayPort connector	
Connector	Part Number: 472720001 Manufacturer: Molex	
Mating Cable	Standard DISPLAYPORT or DISPLAYPORT to HDMI adapter cable	
Pinout	As per DISPLAYPORT	
Notes	The DISPLAYPORT output is capable of supporting HDMI using a DP++ compliant cable adapter.	

## RTC Battery Connector

The Gauntlet allows for an external 3V RTC battery to be connected. For further information about RTC battery selection and life time estimation, see Application Note 00009:

<https://connecttech.com/pdf/CTIN-00009.pdf>.

Function		RTC Battery Connector	
Location	P19		
Type	3 pin PicoBlade (vertical)		
Connector PN	53398-0371 – Manufacturer: Molex		
Mating PN	51021-0300 – Manufacturer: Molex		
Pinout	Pin	Signal	Description
	1	+3V	RTC Battery Voltage Input
	2	NC	No Connect
	3	GND	Ground/Return

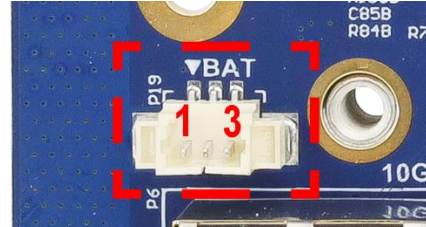

## Fan Connectors

The Gauntlet has 4 Fan connectors available for use with a variety of different fans. Two on the topside (P15, P17) of the card two on the bottom (P16, P18). Note that P15 and P16 are the only connectors with the TACH feedback connected to the module and are flagged as primary.

Function		12V Fan Connectors	
Location	<b>P15, P16, P17, P18</b>		
Type	4 pin PicoBlade (vertical)		
Connector	Part Number: 53398-0471 Manufacturer: Molex		
Mating Cable	Part Number: 51021-0400 (housing), 50058-8000 (contact) Manufacturer: Molex		
Pinout	1 – GND		
	2 – 12V Power		
	3 – TACH feedback (P15 and P16 only)		
	4 – PWM from module to fan		
Notes	P15 and P16 are the Primary 12V fan connectors with TACH feedback, all others do not have TACH feedback connected. P15 is TACH0 and P16 is TACH1.		

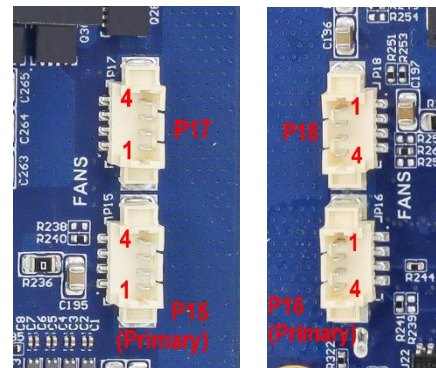

## M.2 M-Key 2280 expansion slots

The Gauntlet has two M.2 M-Key 2280 sized expansion slots, one with x4 PCIe and one with x2 PCIe interface for use with an NVMe or M-key compatible devices.

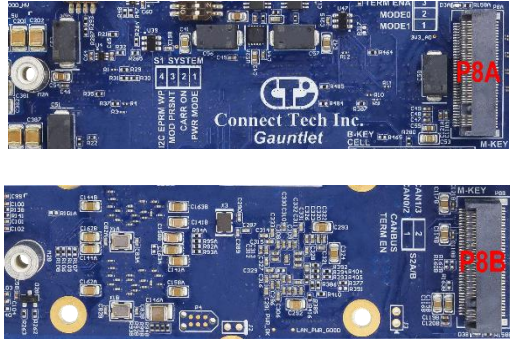
Function	M.2 M-Key 2280 Connectors	
Location	P8A (PCIe x4), P8B (PCIe x2)	
Type	M.2 67pin 8.5mm	
Connector	10131758 series Amphenol	
Pinout	Refer to M.2 M-key specification	
Notes		

## M.2 B-Key 3042/3052 expansion slot

The Gauntlet has one M.2 B-Key 3042/3052 sized expansion slots with USB2 and USB 3.2 interface for use with an LTE or 5G Modem.

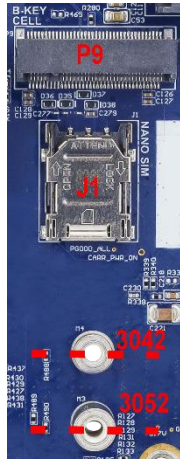
Function	M.2 B-Key 3042/3052 Connector	
Location	P9	
Type	M.2 67pin 8.5mm B-key	
Connector	10128796 series Amphenol	
Pinout	Refer to M.2 B-key specification	
Notes	Includes J1 4FF (nano) top loading SIM card holder. USB Only, No PCIe is available on the B-Key interface	

## M.2 E-Key 2230 expansion slot

The Gauntlet has one M.2 E-Key 2230 sized expansion slots with USB2 and x1 PCIe interface for use with a WiFi and BT expansion card.

Function	M.2 E-Key 2230 Connector
Location	P7
Type	M.2 67pin 8.5mm E-key
Connector	10128797 series Amphenol
Pinout	Refer to M.2 E-key specification
Notes	PCIe x1 capable, USB 2.0 only

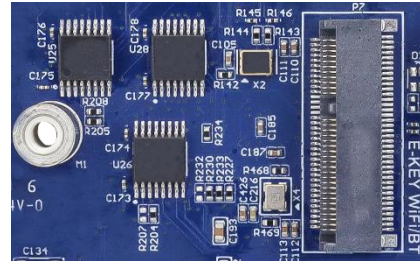

## CAMERA Expansion Connector

Function	8 MIPI CSI-2 Camera Interfaces + I2C and GPIO Control			
Location	P11			
Type	120 Pin QSH with M2.5 mounting standoffs			
Default	Part Number: QSH-060-01-L-D Manufacturer: Samtec			
Mating Connector	QTH			
Pinout	Pin #	Description		Pin #
	1	CSI0_D0_P	CSI1_D0_P	2
	3	CSI0_D0_N	CSI1_D0_N	4
	5	GND	GND	6
	7	CSI0_CLK_P	CSI1_CLK_P	8
	9	CSI0_CLK_N	CSI1_CLK_N	10
	11	GND	GND	12
	13	CSI0_D1_P	CSI1_D1_P	14
	15	CSI0_D1_N	CSI1_D1_N	16
	17	GND	GND	18
	19	CSI2_D0_P	CSI3_D0_P	20
	21	CSI2_D0_N	CSI3_D0_N	22
	23	GND	GND	24
	25	CSI2_CLK_P	CSI3_CLK_P	26
	27	CSI2_CLK_N	CSI3_CLK_N	28
	29	GND	GND	30
	31	CSI2_D1_P	CSI3_D1_P	32
	33	CSI2_D1_N	CSI3_D1_N	34
	35	GND	GND	36
	37	CSI4_D0_P	CSI6_D0_P	38
	39	CSI4_D0_N	CSI6_D0_N	40
	41	GND	GND	42
	43	CSI4_CLK_P	CSI6_CLK_P	44
	45	CSI4_CLK_N	CSI6_CLK_N	46
	47	GND	GND	48
	49	CSI4_D1_P	CSI6_D1_P	50
	51	CSI4_D1_N	CSI6_D1_N	52
	53	GND	GND	54
	55	<b>+12V</b>	<b>+12V</b>	56
	57	<b>+12V</b>	<b>+12V</b>	58
	59	CSI5_D0_P	CSI7_D0_P	60

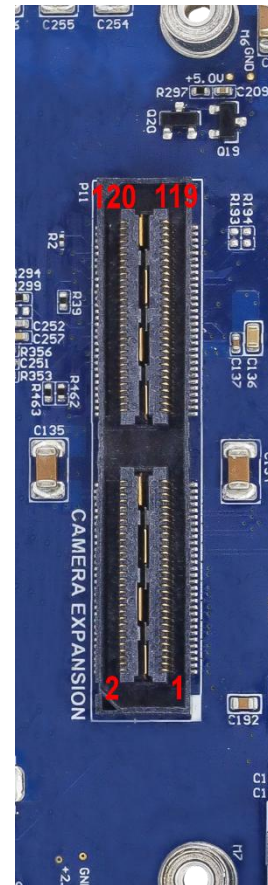

61	CSI5_D0_N	CSI7_D0_N	62
63	GND	GND	64
65	CSI5_CLK_P	CSI7_CLK_P	66
67	CSI5_CLK_N	CSI7_CLK_N	68
69	GND	GND	70
71	CSI5_D1_P	CSI7_D1_P	72
73	CSI5_D1_N	CSI7_D1_N	74
75	I2C3_SCL	CAM_ERROR1	76
77	I2C3_SDA	PWM01	78
79	GND	GND	80
81	+2.8V	+2.8V	82
83	+2.8V	CAM_ERROR3	84
85	FRSYNC1	PWM02	86
87	I2C4_SCL	CAM_MCLK3	88
89	I2C4_SDA	CAM1_PWDN	90
91	CAM_MCLK2	CAM1_RST#	92
93	CAM0_PWDN	CAM_MCLK4	94
95	CAM0_RST#	FRSYNC4	96
97	FRSYNC3	FRSYNC2	98
99	GND	GND	100
101	CAM_ERROR4	1.8V	102
103	CAM_INT3	CAM_INT4	104
105	I2C5_SCL	CAM_INT2	106
107	I2C5_SDA	3.3V	108
109	CAM_ERROR2	3.3V	110
111	CAM_SPI_SCK	CAM_SPI_MOSI	112
113	CAM_SPI_CS0	CAM_SPI_MISO	114
115	GND	GND	116
117	CAM_INT1	3.3V	118
119	CAM_VDD_SYS_EN	3.3V	120
Notes	<p>Only 6 of the CSI2 interfaces can be used at once in 2 lane configurations. Only 4 interfaces when using 4 lane configurations.</p> <p>Note that up to 16 Cameras can be used using virtual channels. All non-CSI-2 I/O (<b>excluding CAM_FRSYNC[1..4]</b>) are 1.8V levels.</p> <p>Power available on the Camera Connector:                      12V =&gt; 3A (4 pins)                      1.8V =&gt; 1A (1 pin)                      2.8V =&gt; 3A (3 pins)                      3.3V =&gt; 3A (4 pins)</p>		

## GPIO/SPI/I2C/UART Connector

Several General purpose I/O features are available on this interface including: 2xSPI, 2xI2C, 2xUART, 4xGPOut, 4xGPIn, 2xPWM\_Out, 2xRS232/RS-485.

Function	General Purpose I/O			
Location	P12			
Type	40 pin General Purpose 3.3V I/O Connector (note: All I/O are 3.3V levels except the RS232/RS485 interfaces)			
Connector	Samtec TFML-020 series			
Mating Cable	CBG630 SFSD-20-28-G-12.00SL (SL or DL = Friction Lock required for locking fit)			
Pinout	Pin #	Description	Description	Pin #
	1	3V3 Power Output (1A)	GND	2
	3	SPI_A_CLK	SPI_A_MOSI	4
	5	SPI_A_CS0#	SPI_A_MISO	6
	7	SPI_B_CLK	SPI_B_MOSI	8
	9	SPI_B_CS0#	SPI_B_MISO	10
	11	GND	GND	12
	13	TTL_UART_A_TX	TTL_UART_B_TX	14
	15	TTL_UART_A_RX	TTL_UART_B_RX	16
	17	I2C_A_CLK	I2C_B_CLK	18
	19	I2C_A_SDA	I2C_B_SDA	20
	21	GP_Out_0	GP_In_0	22
	23	GP_Out_1	GP_In_1	24
	25	GP_Out_2	GP_In_2	26
	27	GP_Out_3	GP_In_3	28
	29	PWM_Out_A	PWM_Out_B	30
	31	GND	GND	32
	33	RS232A_TX/ RS485A_TXP	RS232A_RX/ RS485A_RXP	34

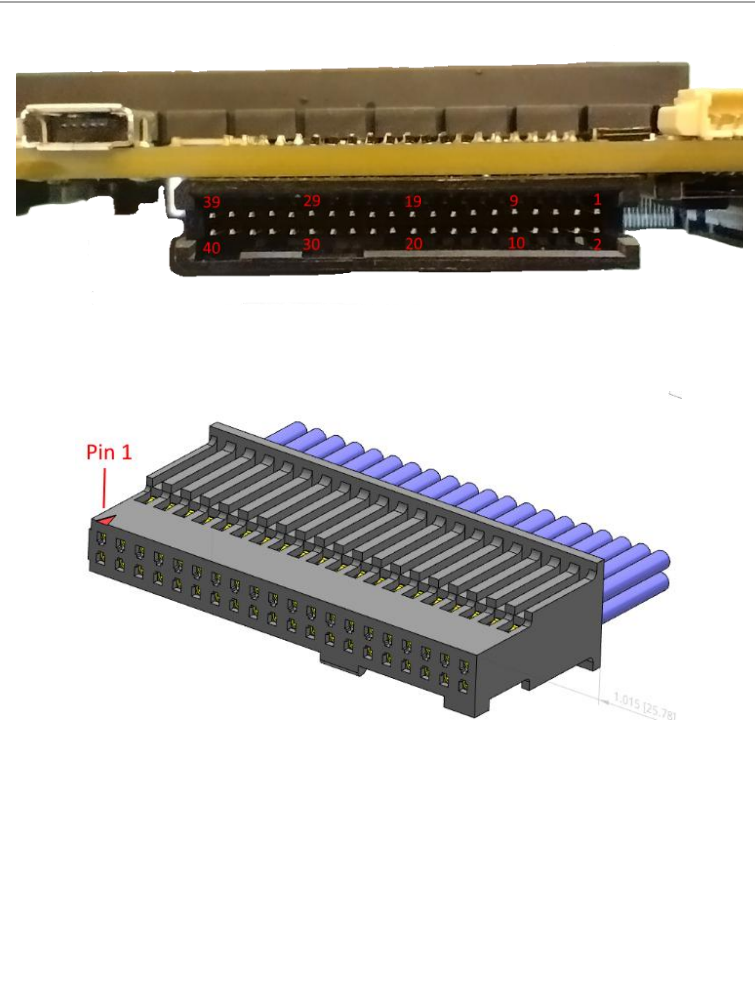

	35	RS232A_RTS/ RS485A_TXN	RS232A_CTS/ RX485A_RXN	36																																																							
	37	RS232B_TX/ RS485B_TXP	RS232B_RX/ RS485B_RXP	38																																																							
	39	RS232B_RTS/ RS485B_TXN	RS232B_CTS/ RS485B_RXN	40																																																							
Notes:	<ul style="list-style-type: none"> <li>All I/O are 3.3V unless otherwise specified.</li> <li>GP_Out_x - are driven outputs and can sink or source 12mA</li> <li>GP_In_x - VIH (Input High Voltage minimum) = 2V. No pullup or pulldown is pre-configured, user discretion to add externally if required for their application.</li> <li>PWM_Out_x - are driven outputs and can sink or source 24mA</li> <li>3V3 Power output can provide up to 1A of current.</li> </ul>																																																										
	SW Cross reference to GPIO controllers			SW Interface Cross reference																																																							
	<table border="1"> <thead> <tr> <th>Connector Name</th> <th>Module ID</th> <th>Controller ID</th> </tr> </thead> <tbody> <tr><td>GP_IN_0</td><td>GPIO32</td><td>PL.01</td></tr> <tr><td>GP_IN_1</td><td>GPIO18</td><td>PL.04</td></tr> <tr><td>GP_IN_2</td><td>GPIO31</td><td>PL.07</td></tr> <tr><td>GP_IN_3</td><td>GPIO67</td><td>PAA.00</td></tr> <tr><td>GP_OUT_0</td><td>I2S7_DIN</td><td>PU.00</td></tr> <tr><td>GP_OUT_1</td><td>GPIO56</td><td>PY.07</td></tr> <tr><td>GP_OUT_2</td><td>GPIO46</td><td>PAL.02</td></tr> <tr><td>GP_OUT_3</td><td>GPIO30</td><td>PAA.02</td></tr> </tbody> </table>			Connector Name	Module ID	Controller ID	GP_IN_0	GPIO32	PL.01	GP_IN_1	GPIO18	PL.04	GP_IN_2	GPIO31	PL.07	GP_IN_3	GPIO67	PAA.00	GP_OUT_0	I2S7_DIN	PU.00	GP_OUT_1	GPIO56	PY.07	GP_OUT_2	GPIO46	PAL.02	GP_OUT_3	GPIO30	PAA.02	<table border="1"> <thead> <tr> <th>Connector Name</th> <th>SW /dev ID</th> <th>DTB ID</th> </tr> </thead> <tbody> <tr><td>I2C_A</td><td>i2c0</td><td>i2c@810c630000</td></tr> <tr><td>I2C_B</td><td>i2c11</td><td>i2c@810c6c0000</td></tr> <tr><td>UART_A</td><td>ttyAMA9</td><td>serial@810c530000</td></tr> <tr><td>UART_B</td><td>ttyAMA4</td><td>serial@810c500000</td></tr> <tr><td>RS232A</td><td>ttyAMA5</td><td>serial@810c510000</td></tr> <tr><td>RS232B</td><td>ttyAMA10</td><td>serial@810c540000</td></tr> <tr><td>SPI_A</td><td>spi4</td><td>spi@810c460000</td></tr> <tr><td>SPI_B</td><td>spi2</td><td>spi@810c440000</td></tr> </tbody> </table>		Connector Name	SW /dev ID	DTB ID	I2C_A	i2c0	i2c@810c630000	I2C_B	i2c11	i2c@810c6c0000	UART_A	ttyAMA9	serial@810c530000	UART_B	ttyAMA4	serial@810c500000	RS232A	ttyAMA5	serial@810c510000	RS232B	ttyAMA10	serial@810c540000	SPI_A	spi4	spi@810c460000	SPI_B	spi2	spi@810c440000
Connector Name	Module ID	Controller ID																																																									
GP_IN_0	GPIO32	PL.01																																																									
GP_IN_1	GPIO18	PL.04																																																									
GP_IN_2	GPIO31	PL.07																																																									
GP_IN_3	GPIO67	PAA.00																																																									
GP_OUT_0	I2S7_DIN	PU.00																																																									
GP_OUT_1	GPIO56	PY.07																																																									
GP_OUT_2	GPIO46	PAL.02																																																									
GP_OUT_3	GPIO30	PAA.02																																																									
Connector Name	SW /dev ID	DTB ID																																																									
I2C_A	i2c0	i2c@810c630000																																																									
I2C_B	i2c11	i2c@810c6c0000																																																									
UART_A	ttyAMA9	serial@810c530000																																																									
UART_B	ttyAMA4	serial@810c500000																																																									
RS232A	ttyAMA5	serial@810c510000																																																									
RS232B	ttyAMA10	serial@810c540000																																																									
SPI_A	spi4	spi@810c460000																																																									
SPI_B	spi2	spi@810c440000																																																									
	<table border="1"> <thead> <tr> <th>Connector Name</th> <th>Module ID</th> <th>DTB ID</th> </tr> </thead> <tbody> <tr><td>PWM_OUT_A</td><td>pwm5</td><td>pwm@810c600000 (PU.07)</td></tr> <tr><td>PWM_OUT_B</td><td>pwm10</td><td>pwm@810c620000 (PV.01)</td></tr> </tbody> </table>			Connector Name	Module ID	DTB ID	PWM_OUT_A	pwm5	pwm@810c600000 (PU.07)	PWM_OUT_B	pwm10	pwm@810c620000 (PV.01)																																															
Connector Name	Module ID	DTB ID																																																									
PWM_OUT_A	pwm5	pwm@810c600000 (PU.07)																																																									
PWM_OUT_B	pwm10	pwm@810c620000 (PV.01)																																																									

## CAN BUS Connectors

Four non-isolated CAN Bus interfaces are available on

Function	CAN Bus Interface			
Location	P13 (CAN0_1), P14 (CAN2_3)			
Type	10 pin dual CAN Bus Connector			
Connector	Samtec TFML-05 series			
Mating Cable	CBG631 SFSD-05-28-G-12.00SL (SL or DL = Friction Lock required for locking fit)			
Pinout	<b>Pin #</b>	<b>Description</b>	<b>Description</b>	<b>Pin #</b>
	1	CAN0_H	CAN0_L	2
	3	GND	GND	4
	5	NC	NC	6
	7	GND	GND	8
	9	CAN1_L	CAN1_H	10
Notes	For P14, the pinout is as described above, except CAN0 is CAN2 and CAN1 is CAN3. Connector pinout allows for it to be rotated without causing damage.			

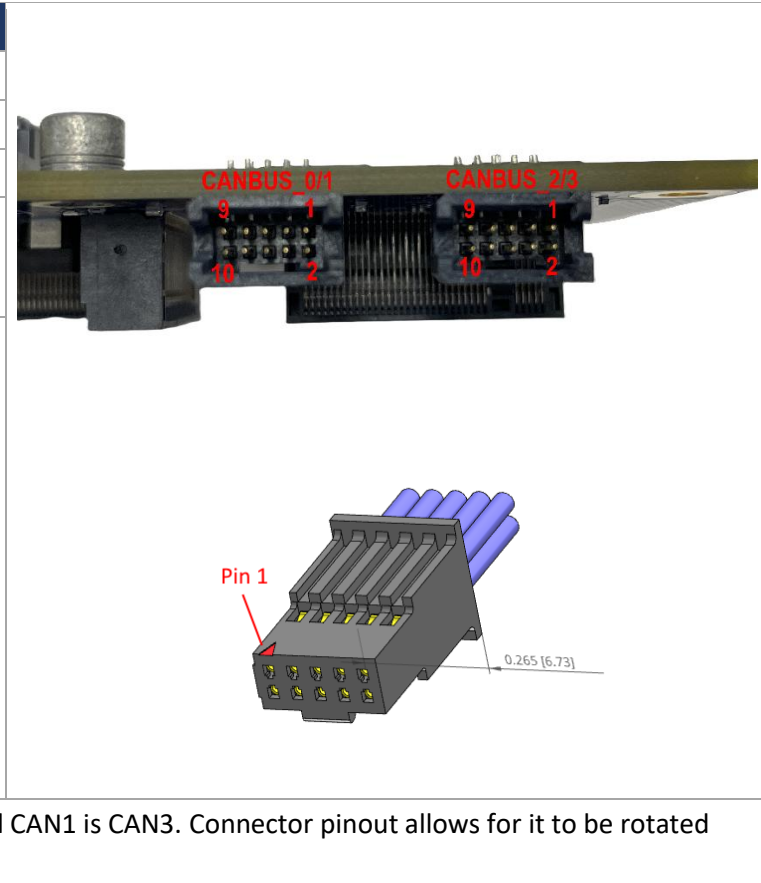

## TYPICAL INSTALLATION

The Gauntlet is an NVIDIA® Jetson Thor™ T5000 based carrier that can be configured in a variety of ways to suit the users environment and feature set. The basic install and power up conditions are as follows:

Ensure all external system power supplies are off.

1. Install the NVIDIA® Jetson Thor™ T5000 Module onto the Molex Mirror Mezz™ Connector. Be sure to follow proper installation of mounting hardware, heatsink/heatspreader, and any other applicable requirements from the manufacturer.
2. Install the necessary cables for application. At a minimum these would include:
  - a) Power cable to the input power connector on the carrier
  - b) Displayport video display cable
  - c) Keyboard and mouse via a USB port
  - or
  - d) Connect only the micro USB debug serial port (no display or keyboard and mouse are necessary) to get a terminal connection from a remote source.

For additional information on the relevant cables, please see the Cables and Interconnects section of this manual.

3. Connect the Power Cable to the Power Supply.

Switch ON the Power Supply. DO NOT power up your system by plugging in live power.

## FORCE RECOVERY MODE

The USB 3.2/DRD Port (P3B) of the Gauntlet can be used to reprogram the Thor™ T5000 from another host platform running NVIDIA Jetpack™.

1. Power down the system completely. The system power MUST be OFF, not in suspend or sleep mode.
2. Connect the DRD USB port to another host device that will be supplying the new system file.
3. Hold down the Force Recovery Button (S5) and then power the board.
4. After three (3) seconds release the Recovery button.
5. The Thor™ T5000 will show up on the host system USB list as a new NVIDIA target device.
6. After successfully updating the system software, power off the system. A clean power up will revert the DRD port back into host mode.

## POWER CONSUMPTION & THERMALS

Module TDP is approximately 130W, with system transient power draws up to 300% of TDP. Appropriate selection of input power source is required to ensure system stability. **Connect Tech recommends an input power source of 48V / 360W PSU that is capable of 400W+ peak power.**

Theoretical Maximum System power	Watts
Theoretical maximum system power with T5000 module (MAXN Power Mode): <ul style="list-style-type: none"> <li>- Module = 130W</li> <li>- 2x USB 3.2 load 5V@3A each = 30W</li> <li>- 2x 10GbE linked = 6W</li> <li>- 2x 1GbE linked = 3W</li> <li>- 8x GMSL camera with PoC (12V power over coax) = 40W</li> <li>- 2x NVMe = 20W</li> <li>- 1x Wi-Fi = 3W</li> <li>- 1x LTE = 6W</li> </ul>	238W

The typical power consumption will vary depending on the application and use case.

Tested System Power Scenarios	Watts
<ul style="list-style-type: none"> <li>- Module (MAXN Power Mode)</li> <li>- 1x display</li> <li>- Apps running: video search and summarization + a local LLM</li> <li>- 2x NVMe, main used for AI models, secondary undergoing stress test (repetitive dd)</li> <li>- 1x 3A USB load</li> <li>- 10G loopback test</li> </ul>	140W average, 385W instantaneous
<ul style="list-style-type: none"> <li>- Idle system</li> <li>- Module in 70W power mode</li> <li>- 1x display</li> </ul>	18.5W

It is important to note that the NVIDIA® Jetson Thor™ module has its own properties separate to that of the peripherals.

Parameter	Value	Units
Jetson Thor™ SoC maximum operating temperature top of case (TTP)	80	°C
Jetson Thor™ SoC recommended operating temperature	90	°C
Jetson Thor™ SoC maximum temperature	115	°C

Connect Tech has two heatsinks for the Jetson Thor™ T5000:

1. XHG332 Jetson Thor™ Active Cooling
2. XHG333 Jetson Thor™ Passive Cooling

Using the XHG332, the system has an operating temperature range of -25°C to 60°C.

Tested System Thermal Scenarios	Watts	SoC Temperatures
<ul style="list-style-type: none"> <li>- Module (MAXN Power Mode)</li> <li>- 1x display</li> <li>- LLM doing repetitive Q&amp;A</li> <li>- Stress -c 14</li> <li>- Thor Active Heatsink with 100% fan PWM</li> <li>- Thermal chamber temperature: 62.5°C +/- 2.5°C</li> </ul>	CPU: 50 – 53W GPU: 51 – 56W 5V: 21 – 23W	CPU: 102.8 – 109.5°C GPU: 101 – 108.4°C SOC012: 101.3 – 108.7°C SOC345: 99.7 – 108.2°C

Notes:

- 1: System load is variable, and changes depending on actual processor usage.
- 2: Module starts thermally throttling at 109°C. During testing, throttling was observed when the chamber temperature and module power draws were on the higher end of the specified ranges. To ensure your system does not throttle, do not exceed an ambient temperature of 60°C.
- 3: If you want to keep the temperature of the SoC below 90°C, decrease module usage or ambient temperature, or both.
- 4: Tj has been omitted since it follows the same range as the CPU temperature

Using the XHG333, the system has an operating temperature range of -25°C to 55°C with external airflow of 5 m/s.

Tested System Thermal Scenarios	Watts	SoC Temperatures
<ul style="list-style-type: none"> <li>- Module (MAXN Power Mode)</li> <li>- 1x display</li> <li>- LLM doing repetitive Q&amp;A</li> <li>- Stress -c 14</li> <li>- Thor Passive Heatsink with 5m/s external airflow</li> <li>- Thermal chamber temperature: 57.5°C +/- 2.5°C</li> </ul>	CPU: 52 – 54W GPU: 53 – 55W 5V: 21 – 22W	CPU: 104.8 – 109°C GPU: 104.5 – 108.8°C SOC012: 104.7 – 109.2°C SOC345: 102.2 – 106.5°C

Notes:

- 1: System load is variable, and changes depending on actual processor usage.
- 2: Module starts thermally throttling at 109°C. During testing, throttling was observed when the chamber temperature and module power draws were on the higher end of the specified ranges. To ensure your system does not throttle, either increase airflow, or reduce ambient temperature.
- 3: If you want to keep the temperature of the SoC below 90°C, decrease module usage or ambient temperature, or both.
- 4: Tj has been omitted since it follows the same range as the CPU temperature

## WEIGHT

Gauntlet configuration	Weight in grams
AGX301 board only (no module) with ethernet phy heat spreader (TTP) attached	266g

## CABLES

**CBG630** (GPIO connector) – 12” breakout cable with flying leads is supplied with the board purchase.

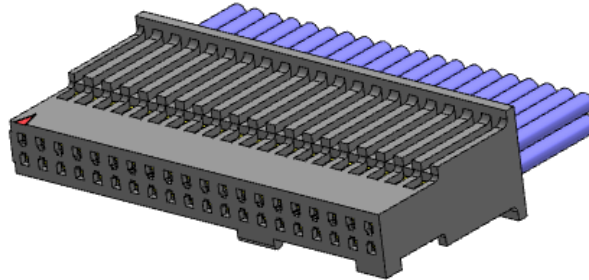

**CBG631** (CAN Bus) – 12” breakout cable with flying leads is supplied with the board purchase.

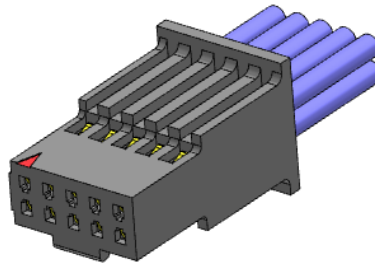

**CBG632** (POWER) – 12” 6 pin to 6 pin Mini-Fit Jr for use with power connections, supplied with the board purchase.

