

# ROM-7720

## NXP ARM Cortex-A72 i.MX8 QuadMax Qseven 2.1 Module

Preliminary

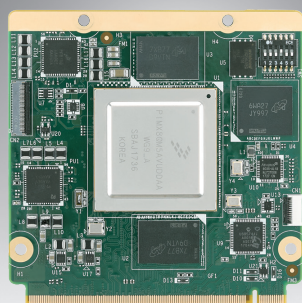

## Introduction

ROM-7720 Qseven 2.1 Module powered by i.MX8 QuadMax Processor, which compose eight cores, including 2 ARM Cortex-A72 cores, 4 Cortex-A53 cores and 2 Cortex-M4F cores into one single package. ROM-7720 also escalate its graphic performance by dual 32-core GPU subsystems, 4K H.265 capable VPU, and dual failover-ready display controllers. The enhanced HAB secure & encrypted boot bring you a worry-free module platform for surveillance an video analysis application.

## Specifications

Form Factor		Qseven 2.1
Processor System	CPU	NXP ARM Cortex-A72 i.MX8 QuadMax 1.6GHz 8 -Core Processor
Memory	Technology	LPDDR4 1600
	Capacity	On-board DDR4 2 GB
	Flash	8 GB eMMC NAND Flash for O.S. and 64 MB Quad SPI Flash for boot loader
Graphics	LVDS	2 x 24-bit LVDS, 1366 x 768 for 1ch; 1920 x 1080 for 2ch
	HDMI	4K @ 30fps
	Graphics Engine	TBD
	H/W Video Codec	Decoder: MPEG-4 ASP, H.265 HP, H.264 HP, H.263, MPEG-2 MP, MJPEG BP Encoder: MPEG-4 SP, H.265 BP, H.264 BP, H.263, MJPEG BP
Ethernet	Chipset	NXP i.MX8 integrated RGMII
	Speed	1 x 10/100/1000 Mbps
RTC	RTC	Yes
WatchDog Timer		HW Watchdog Timer
I/O (Edge finger)	PCIe	2 PCIe
	SATA	1 SATA III
	USB	3 USB 3.0, 1 USB OTG
	I <sup>2</sup> S	1
	SPDIF	-
	SDIO	1
	Serial Port	2 UART (4 wire)
	SPI	1
	CAN	1
	GPIO	8
	I <sup>2</sup> C	2
	System Bus	-
	Fan Control (PWM)	2
	Keypad	-
I/O (On board)	UART	1 (for console)
	SD	-
	Camera	-
Power	Power Supply Voltage	5 V
	Power Consumption	TBD
Environment	Operational Temperature	0 ~ 60° C
	Operating Humidity	5 ~ 95% relative humidity, non-condensing
Mechanical	Dimensions (W x D)	70 x 70 mm
Certifications		CE/FCC Class B

## Features

- NXP ARM Cortex-A72 + A53 i.MX8 QuadMax 1.6GHz high performance processor
- Onboard DDR4 memory 2 GB
- Onboard eMMC NAND Flash 8 GB
- Supports OpenGL 3.0, 2.1; OpenGL ES 3.2; Open GL ES 3.1 (with AEP); Open GL ES 3.0, 2.0, and 1.1; OpenCL 2.0 and 1.1; OpenVG 1.1; and Vulkan
- HDMI 4K, Dual Channel 24bit LVDS
- 1 CAN, 2 UART, 2 I2C, 8 GPIO, 1 I2S
- 3 USB 3.0; 1 USB OTG
- 1 SDIO, 1 SATA III
- 1 10/100/1000 Mbps Ethernet; 2 PCIe x1 Gen2
- Optional thermal solution

## Block Diagram

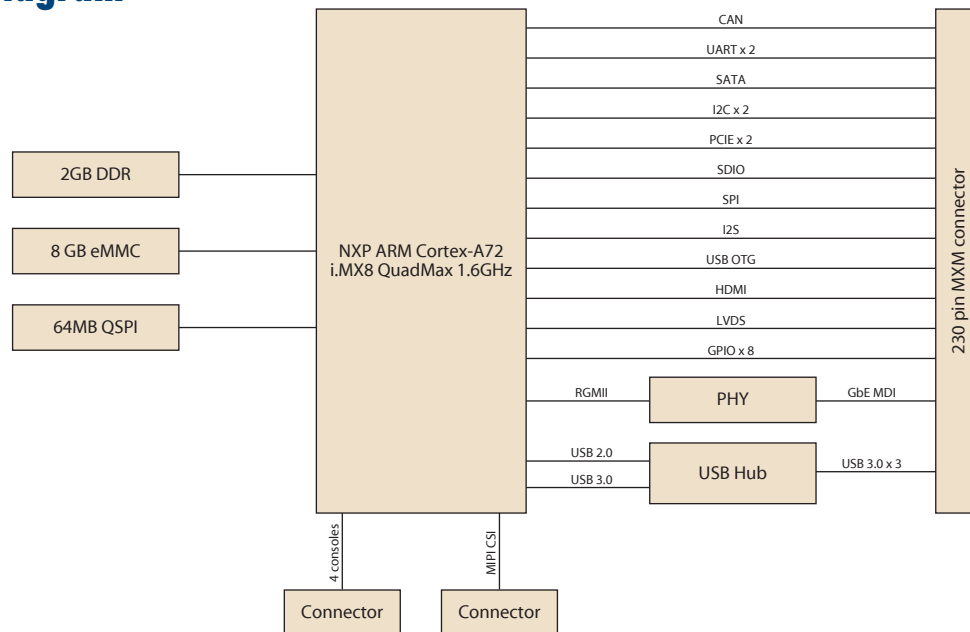

## OS Specification

Operating System	Version Support
Linux	Yocto 2.1 and later version
Android	Android 6.0 and later version

## SW Specification

Software Application	Function Support
SUSI API	I2C, GPIO, SPI, WDT, RTC, Backlight Control
WISE-Paas/EdgeSense	Optional
WISE-Paas/RMM	Built-in
WISE-Paas/OTA	Built-in
mbed Edge	Optional
Licensing Mechanism	Built-in
Secure Boot	Optional
Multi Boot	Built-in
Quick Boot	Optional

## Optional Accessories

Part No.	Description
1700022373-01	Debug Port Cable for ROM-7720
9696ED2000E	Debug Port Adapter for ROM-7720
96PSA-A36W12R1	ADAPTER 100-240V 36W 12V 3A
1700001524	Power Cord 3P UL 10A 125V 180cm
170203183C	Power Cord 3P Europe (WS-010+WS-083)183cm
170203180A	Power Cord 3P UK 2.5A/3A 250V 1.83M
1700008921	Power Cord 3P PSE 183cm
SQF-ISDS1-2G-86E	SQFlash SD card SLC 2G, 1CH (-40 ~ 85° C)
EWM-W142F01E	802.11 b/g/n,AR9287,2T2R,Full size Mini PCIe
1750007050-01	WiFi RP-SMA short SMA Jack(9.5mm) to U.FL_100mm (WiFi Cable)
1750000318	EMI Antenna 2DBI 2.4GHz SMA CONN for ARK-3384 (WiFi Antenna)
968EMW0093	Telit HE910-D Mini PCIe
1750007156-01	Cellular/GPS SMA Short JACK(9.5MM) L=100mm (3G Cable)
1750005865	Antenna L=10.9cm 500hm AN8921F-5701SM (3G Antenna)

## Ordering Information

Part No.	CPU	Memory	Flash Memory	UART	LAN	USB Host	USB OTG	Display	SATA	PCIE	HDMI	SD	CANbus	I <sup>2</sup> C	SPI	Size	Power Input	Operating Temperature
ROM-7720CO-QEA1E	i.MX8 Quad Max 1.6GHz	2 GB	8 GB	2	1	6	1	2 x 24-bit LVDS	1	2	1	1	1	2	2	70 x 70 x 5mm	5V	0 ~ 60° C

## Development Board

Part No.	Description
ROM-DB7503-SCA1E	Development board for RISC Qseven 2.1 module