

PCA-6154/6154L

Half-size all-in-one Pentium® CPU
card with VGA and fast Ethernet
interface

Copyright Notice

This document is copyrighted, 1998. All rights are reserved. The original manufacturer reserves the right to make improvements to the products described in this manual at any time without notice.

No part of this manual may be reproduced, copied, translated or transmitted in any form or by any means without the prior written permission of the original manufacturer. Information provided in this manual is intended to be accurate and reliable. However, the original manufacturer assumes no responsibility for its use, nor for any infringements upon the rights of third parties which may result from its use.

Acknowledgements

AMD is a trademark of Advanced Micro Devices, Inc.

Award is a trademark of Award Software International, Inc.

Cyrix is a trademark of Cyrix Corporation.

IBM, PC/AT, PS/2 and VGA are trademarks of International Business Machines Corporation.

Intel and Pentium are trademarks of Intel Corporation.

Microsoft Windows® is a registered trademark of Microsoft Corp.

RTL is a trademark of Realtek Semi-Conductor Co., Ltd.

SiS is a trademark of Silicon Integration Systems Corporation.

UMC is a trademark of United Microelectronics Corporation.

ITE is a trademark of Integrated Technology Express, Inc.

All other product names or trademarks are properties of their respective owners.

For more information on this and other Advantech products please visit our website at: <http://www.advantech.com>
<http://www.advantech.com/epc>

For technical support and service for please visit our support website at: <http://support.advantech.com>

This manual is for the PCA-6154/PCA-6154L Rev. A3

Part No. 2006615404

Printed in Taiwan

4th Edition

July 1999

Packing List

Before installing your board, ensure that the following materials have been received:

- 1 PCA-6154/6154L all-in-one single board computer
- 2 utility disk with Ethernet utility programs (PCA-6154 only)
- 1 utility disk with IDE utility programs
- 6 utility disks with SVGA utility programs and drivers for Windows 3.1/95/NT and OS/2
- 1 hard disk drive (IDE) interface cable (40 pin)
- 1 floppy disk drive interface cable (34 pin)
- 1 parallel port adapter (26 pin) and COM2 adapter (9 pin) kit
- 1 USB cable
- 1 CPU fan with heatsink
- 1 6-pin mini-DIN keyboard & PS/2 mouse adapter
- 1 warranty certificate

If any of these items are missing or damaged, contact your distributor or sales representative immediately.

Optional Devices

- IrdA adapter (part#: 968900042)

Contents

Chapter 1 Hardware Configuration	1
1.1 Introduction	2
1.2 Specifications	3
1.3 Board Layout: Dimensions	5
1.4 Jumpers and Connectors	6
1.6 Board Layout: Connector Locations	8
1.5 Board Layout: Jumper Locations	9
1.7 Safety Precautions	10
1.8 Jumper Settings	10
1.8.1 CPU clock ratio select (JP2)	11
1.8.2 CPU core voltage select (JP3)	12
1.8.3 Watchdog timer configuration (JP4)	12
1.8.4 COM2 settings for RS-232/422/485 (JP8)	13
1.8.5 DOC2000 address setting (JP7)	14
1.8.6 CMOS backup select (JP5)	14
1.8.7 DLL circuit for CPU clock optimization (JP10)	14
1.8.8 Buzzer enable/disable (CN16)	15
1.9 Installing DRAM (SIMMs)	15
1.9.1 Installing SIMMs	15
Chapter 2 Connecting Peripherals	17
2.1 Enhanced IDE Connector (CN1)	19
2.2 VGA Display Connector (CN7)	20
2.3 Floppy Drive Connector (CN2)	20
2.4 Parallel Port Connector (CN3)	20
2.5 Keyboard & PS/2 Mouse Connector (CN15)	21
2.6 Front Panel Connector (CN16)	21
2.7 Hard Disk Drive LED (CN17)	22

2.8	Serial Ports (CN11: COM1; CN10: COM2)	22
2.8.1	RS-232 connection (COM1-CN11)	22
2.8.2	RS-232/422/485 connection (COM2-CN10)	23
2.9	Power Connectors	23
2.9.1	Main power connector +5 V, +12 V, -12 V (CN6) ...	23
2.9.2	CPU fan power supply connector (CN4)	23
2.10	Ethernet Configuration (PCA-6154 Only)	24
	RJ-45A connector (CN8)	24
	Network boot	24
2.11	USB Connector (CN9)	24
2.12	IR Connector (CN5)	24
Chapter 3	VGA Display & Ethernet Software Configuration	25
3.1	Introduction	26
3.2	Utility Disk	26
3.3	VGA Display Software Configuration	27
3.4	Ethernet Software Configuration	27
Chapter 4	Award BIOS Setup	29
4.1	AWARD BIOS Setup	30
4.1.1	Entering setup	30
4.1.2	Standard CMOS setup	31
4.1.3	BIOS features setup	32
4.1.4	CHIPSET features setup	36
4.1.5	Power management setup	37
4.1.6	PCI configuration setup	38
4.1.7	Load BIOS defaults	38
4.1.8	Load setup defaults	38
4.1.9	Integrated Peripherals	39
4.1.10	Password setting	39
4.1.11	IDE HDD auto detection	39
4.1.12	Save & exit setup	40
4.1.13	Exit without saving	40

Chapter 5 PCI SVGA Setup	41
5.1 Before You Begin	42
5.2 Installation	42
5.3 Driver Installation	43
5.3.1 Windows setup	43
5.3.2 DOS setup	44
5.4 Windows 95 Drivers Setup Procedure	46
5.5 Windows NT Drivers Setup Procedure	46
5.6 OS/2 Drivers Setup Procedure	47
Preliminary steps	47
Installing from diskette	47
Selecting monitor type	49
Selecting screen resolution/refresh rate	49
Installation notes	50
Appendix A Programming the Watchdog Timer ...	51
A.1 Programming the watchdog timer	52
Appendix B Installing PC/104 Modules	55
B.1 Installing PC/104 modules	56
Appendix C Pin Assignments	59
C.1 CRT Display Connector (CN7)	60
C.2 COM1 RS-232 Serial Port (CN11)	60
C.3 COM2 RS-232/422/485 Serial Port (CN10)	61
C.4 Keyboard and Mouse Connector (CN15)	61
C.5 External Keyboard Connector (CN14)	62
C.6 Main Power Connector (CN6)	62
C.7 IDE Hard Drive Connector (CN1)	63
C.8 USB Connector (CN9)	64
C.9 CPU Fan Power Connector (CN4)	64
C.10 Front Panel Connector (CN16)	65
C.11 Ethernet RJ-45 Connector (CN8)	65
C.12 Floppy Drive Connector (CN2)	66

C.13	Parallel Port Connector (CN3)	67
C.14	IR Connector (CN5)	68
C.15	HDD LED Connector (CN17)	68
C.16	System I/O Ports	69
C.17	DMA Channel Assignments	70
C.18	Interrupt Assignments	71
C.19	1st MB Memory Map	71
Appendix D DOC® 2000 Installation Guide		73
D.1	DiskOnChip® 2000 Quick Installation Guide	74
	DiskOnChip® 2000 installation instructions	74
	Additional information and assistance	75

Tables

Table 1-1: PCA-6154/6154L jumpers	6
Table 1-2: PCA-6154/6154L connectors	7
Table 1-3: CPU clock ratio select (JP2)	11
Table 1-4: CPU speed reference table	11
Table 1-5: System/PCI clock setting (JP9)	12
Table 1-6: CPU voltage select (JP3)	12
Table 1-7: Watchdog timer system reset select (JP4)	13
Table 1-8: COM2 settings for RS-232/422/485 (JP8)	13
Table 1-9: DOC2000 address setting (JP7)	14
Table 1-10: RTC power and CMOS clear (JP5)	14
Table 1-11: DLL circuit for CPU clock optimization (JP10) ...	14
Table 1-12: Buzzer enable/disable (CN16)	15
Table 2-1: Connectors	18
Table 2-2: Serial port connections (COM1, COM2)	22
Table 2-3: PCA-6154/L serial port default settings	23
Table C-1: PCA-6154/L CRT display connector	60
Table C-2: PCA-6154/L COM1 RS-232 serial port	60
Table C-3: PCA-6154/L COM2 RS-232/422/485 series port .	61
Table C-4: PCA-6154/L keyboard and mouse connector	61
Table C-5: PCA-6154/L external keyboard connector	62
Table C-6: PCA-6154/L main power connector	62
Table C-7: PCA-6154/L IDE hard drive connector	63
Table C-8: USB1/USB2 connector	64
Table C-9: PCA-6154/L CPU fan power connector	64
Table C-10: PCA-6154/L front panel connector	65
Table C-11: PCA-6154/L Ethernet RJ-45 connector	65
Table C-12: PCA-6154/L floppy drive connector	66
Table C-13: PCA-6154/L parallel port connector	67
Table C-14: PCA-6154/L IR connector	68
Table C-15: PCA-6154/L HDD LED connector	68
Table C-16: System I/O ports	69
Table C-17: DMA channel assignments	70
Table C-18: Interrupt assignments	71
Table C-19: 1st MB memory map	71

Figures

Figure 1-1: PCA-6154/6154L board layout: Dimensions	5
Figure 1-2: PCA-6154/6154L board layout: Jumper locations..	9
Figure 1-3: PCA-6154/6154L board layout: Connector locations	8
Figure 4-1: Setup program initial screen	30
Figure 4-2: CMOS setup screen	31
Figure 4-3: BIOS features setup screen	32
Figure 4-4: CHIPSET features setup screen	36
Figure 4-5: Power management setup screen	37
Figure 4-6: PCI configuration screen	38
Figure 4-7: Integrated peripherals	39
Figure B-1: PC/104 module mounting diagram	57
Figure B-2: PC/104 module dimensions (inches) ($\pm 5\%$)	57

Hardware Configuration

This chapter gives background information on the PCA-6154/6154L. It then shows you how to configure the card to match your application and prepare it for installation into your PC.

Sections include:

- Card specifications
- Board layout: dimensions
- Board layout: jumper locations
- Board layout: connector locations
- Safety precautions
- Jumper settings
- Installing DRAM (SIMMs)

1.1 Introduction

The PCA-6154/6154L is a cost-effective, all-in-one single board Pentium® processor-based CPU card which can release the Pentium processor's full potential and provide unprecedented performance compared to current 64-bit processor board. The PCA-6154/6154L offers all the functions of an industrial computer on a single board, half-size CPU card. This card uses an Intel Pentium, Pentium MMX, AMD K5, AMD K6, AMD K6-2, Cyrix M1 or Cyrix M2 processor. The card accepts up to 128 MB DRAM. It is also equipped with 512 KB PB-SRAM 2nd level cache.

The PCA-6154/6154L uses a single-chip solution, allowing on-board DRAM to be shared with the built-in VGA controller. In this configuration, the chipset always acts as the arbiter between memory bus masters. This system ensures efficient memory allocation while substantially reducing the overall system cost.

On-board features include 512 KB 2nd level cache memory, 100/10 Mbps fast Ethernet interface (PCA-6154 only), one RS-232 port, one RS-232/422/485 port, one multi-mode parallel (ECP/EPP/SPP) port, a floppy drive controller and a keyboard and PS/2 mouse interface. The built-in high speed PCI IDE controller supports both PIO and bus master modes. Up to two IDE devices can be connected, including large hard disks, CD-ROM drives, tape backup drives and other IDE devices. The PCA-6154/6154L also supports two USB ports and one fast infrared port.

The PCA-6154/6154L also features power management to minimize power consumption. It complies with the "Green Function" standard and supports three types of power saving features: Doze mode, Standby mode and Suspend mode. A watchdog timer can automatically reset the system or generate an interrupt should the system stop due to a program bug or EMI.

1.2 Specifications

Standard SBC functions

- **CPU:** Intel Pentium® 100 ~ 233 MHz, Pentium MMX, AMD K5, AMD K6 200 / 266 MHz, AMD K6-2 266 ~ 300 MHz, Cyrix M1, Cyrix M2 up to PR-300 MHz, or IDT Win Chip C6 upto 200 MHz
- **BIOS:** Award 256 KB (2Mbit) memory; supports plug and play, suspend to disk
- **Chipset:** SiS5598
- **L2 cache:** On-board 512 KB synchronous (pipeline burst) SRAM
- **Green function:** Features power management option via BIOS, activated by keyboard or mouse activity. Supports doze, sleep and suspend modes. APM 1.1 compliant
- **RAM:** Two 72-pin SIMM sockets. Supports 32-bit FPM or EDO DRAM with memory capacity from 8 ~ 128 MB.
- **EIDE interface:** Handles up to two IDE HDDs or other IDE devices. Supports PIO mode 4 and Ultra DMA mode
- **FDD interface:** Supports up to two floppy disk drives.
- **Parallel port:** Configured to LPT1, LPT2, LPT3 or disabled. Supports multi-mode parallel port (SPP/ECP/EPP)
- **Serial ports:** Two 16C550 UARTs, one RS-232, one RS-232/422/485 interface
- **Watchdog timer:** Can generate a system reset. Software enabled/disabled. Time interval is from 1 to 63 seconds, jumperless with run-time setup
- **Keyboard/mouse connector:** 6-pin mini-DIN connector on the mounting bracket eases connection to a keyboard or PS/2 mouse. An on-board keyboard pin header connector is also available.
- **I/O bus expansion:** PC/104 connector with face-up installation
- **USB interface:** Two USB connectors with fuse protection. Complies with USB specification 1.0
- **Infrared port:** Fast IrDA. Transfer rate up to 4 Mbps. I/O port programmable to COM1 (3F8), COM2 (2F8), COM3 (3E8) or COM4 (2E8).

VGA interface

- **Chipset:** SiS5598 built-in VGA function
- **Architecture:** Universal memory architecture
- **Display memory:** Share system RAM 1 MB ~ 4 MB

100Base-T Ethernet interface (PCA-6154 only)

- **Chipset:** REALTEK RTL8139. PCI bus 100/10 Mbps Ethernet controller
- **I/O Address jumperless setting**
- **Built-in boot ROM**

SSD function

- **Supports M-System's DiskOnChip® 2000 Flash Disk up to 72 MB**

Mechanical and environmental specifications

- **Board size:** 185 x 122 mm
- **Max. power requirements:** +5 V @ 5.5 A, +12 v @ 100 mA
- **Operating temperature:** 0 ~ 60° C (32 ~ 140° F)
- **Board weight:** 0.5 kg (1.2 lb)

1.3 Board Layout: Dimensions

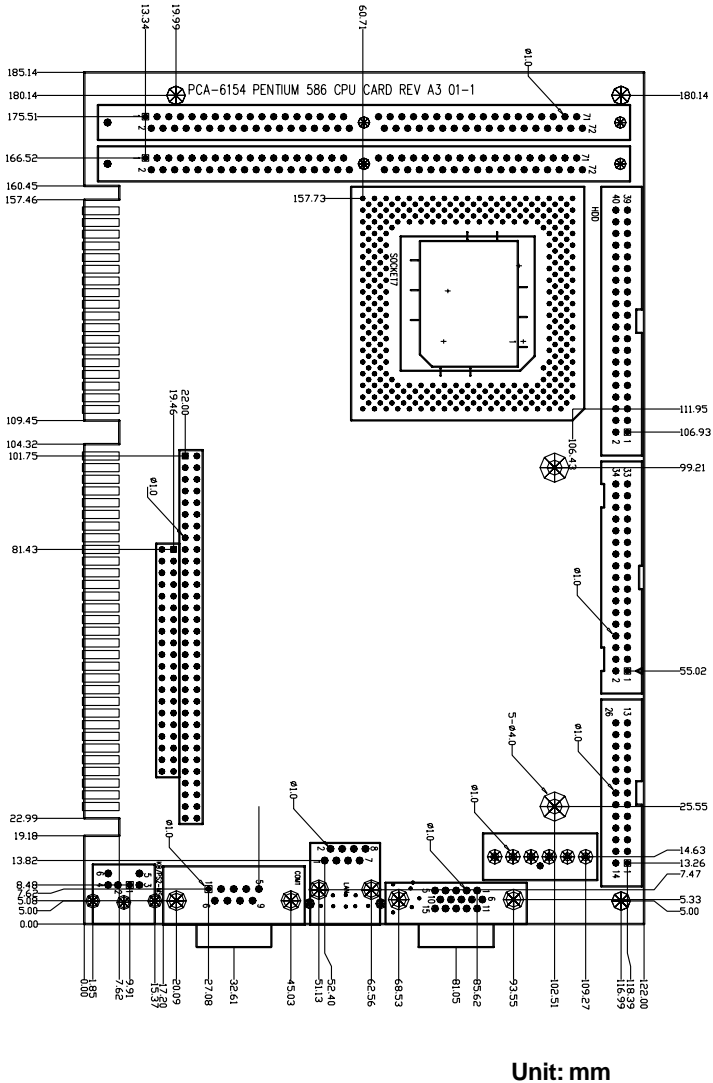

Figure 1-1: PCA-6154/6154L board layout: Dimensions

1.4 Jumpers and Connectors

On-board connectors link it to external devices such as hard disk drives, a keyboard, or floppy drives. In addition, the board has jumpers for configuring your board for specific applications.

The table below lists the function of each of the board's jumpers and connectors. Later sections in this chapter give instructions on setting jumpers and detailed information on each jumper setting. Chapter 2 gives instructions for connecting external devices to your card.

Table 1-1: PCA-6154/6154L jumpers

Number	Function
JP2	CPU clock ratio select
JP3	CPU core voltage select
JP4	Watchdog timer select
JP5	Real-time clock (RTC) power and CMOS select
JP7	DiskOnChip® 2000 Flash disk memory segment
JP8	COM2 RS-232/422/485 selection
JP9	CPU clock select
JP10	CPU clock optimize enable

Table 1-2: PCA-6154/6154L connectors

Number	Function
CN1	IDE port
CN2	Floppy disk connector
CN3	Parallel port
CN4	CPU fan power connector
CN5	Infra red port
CN6	Main power connector
CN7	VGA connector
CN8	100/10 Mbps network connection (PCA6154 only)
CN9	USB 1 and USB 2 ports
CN10	COM2 port
CN11	COM1 port
CN12	PC/104 A ₁ ~ A ₃₂ , B ₁ ~ B ₃₂
CN13	PC/104 C ₁ ~ C ₂₀ , D ₁ ~ D ₂₀
CN14	External keyboard
CN15	Keyboard and PS/2 mouse
CN16	Front panel connector
CN17	HDD LED

Please refer to Appendix C for pin assignments.

1.5 Board Layout: Jumper Locations

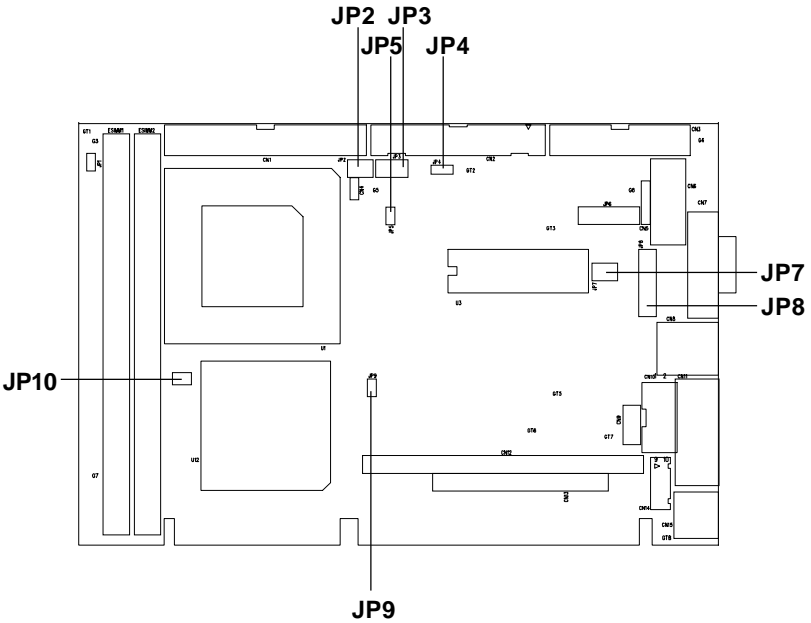

Figure 1-2: PCA-6154/6154L board layout: Jumper locations

1.6 Board Layout: Connector Locations

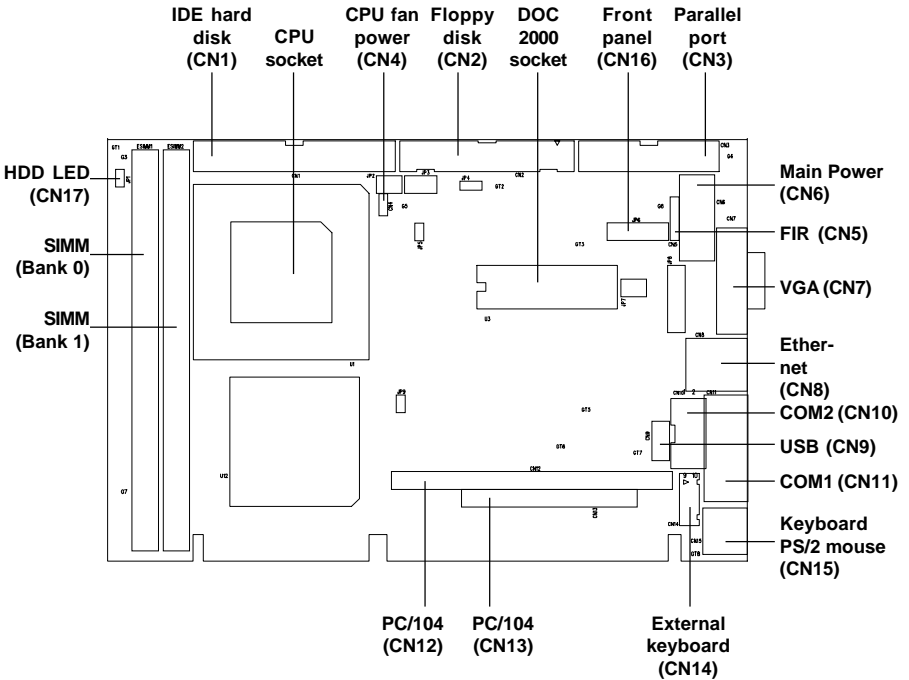

Figure 1-3: PCA-6154/6154L board layout: Connector locations

1.7 Safety Precautions

Follow these simple precautions to protect yourself from harm and your PC from damage.

1. To avoid electric shock, always disconnect the power from your PC chassis before you work on it. Don't touch any components on the CPU card or other cards while the PC is on.
2. Disconnect power before making any configuration changes. The sudden rush of power as you connect a jumper or install a card may damage sensitive electronic components.
3. Always ground yourself to remove any static charge before you touch your CPU card. Be particularly careful not to touch the chip connectors. Modern integrated electronic devices, especially CPUs and memory chips, are extremely sensitive to static electric discharges and fields. Keep the card in its antistatic packaging when it is not installed in the PC, and place it on a static dissipative mat when you are working with it. Wear a grounding wrist strap for continuous protection.

1.8 Jumper Settings

This section tells how to set the jumpers to configure your card. It gives the card default configuration and your options for each jumper. After you set the jumpers and install the card, you will also need to run the BIOS Setup program (discussed in Chapter 3) to configure the serial port addresses, floppy/hard disk drive types and system operating parameters. Connections, such as hard disk cables, appear in Chapter 2. For the locations of each jumper, see the board layout diagram depicted earlier in this chapter.

You configure your card to match the needs of your application by setting jumpers. A jumper is the simplest kind of electric switch. It consists of two metal pins and a small metal cap (often protected by a plastic cover) that slides over the pins to connect them. To "close" a jumper you connect the pins with the cap. To "open" a jumper you remove the cap. Sometimes a jumper will have three pins, labeled 1, 2 and 3. In this case you connect either pins 1 and 2 or 2 and 3.

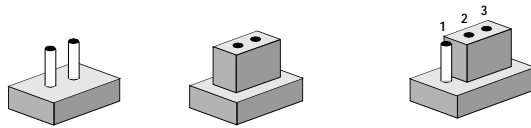

Open

Closed

Closed 2-3

You may find a pair of needle-nose pliers useful for setting the jumpers.

If you have any doubts about the best hardware configuration for your application, contact your local distributor or sales representative before you make any changes.

1.8.1 CPU clock ratio select (JP2)

In order for the system to function properly, the jumpers must be set to accommodate the CPU installed on the CPU card.

Table 1-3: CPU clock ratio select (JP2)

Pentium CPU, AMD K5, Cyrix M1, IDT C6

100 MHz 1.5 x 66	2 1		166 MHz 2.5 x 66	2 1	
*133 MHz 2 x 66	2 1		200 MHz 3 x 66	2 1	
150 MHz 2 x 75	2 1		233 MHz 3.5 x 66	2 1	
266 MHz 4 x 66	2 1		300 MHz 4.5 x 66	2 1	

* default setting



Refer to the CPU speed reference table (below) for instructions on adjusting the internal clocks according to the base CPU speed.

Table 1-4: CPU speed reference table

CPU Speed (MHz)	100	*133	150	166	200	233	266	300
Clock setting	66	66	75	66	66	66	66	66
Frequency ratio	1.5	2	2	2.5	3	3.5	4	4.5

* default setting

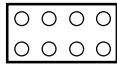
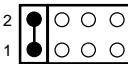
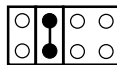
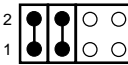
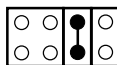
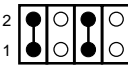
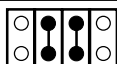
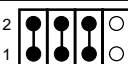
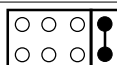
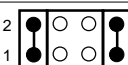
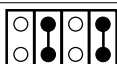
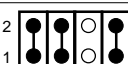
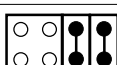
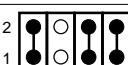

Table 1-5: System/PCI clock setting (JP9)

System (MHz)	*66	75
PCI (MHz)	33	37.5
JP9		

* default setting

1.8.2 CPU core voltage select (JP3)

Table 1-6: CPU voltage select (JP3)

Voltage	JP3	Voltage	JP3
1.9 V		2.0 V	
2.2 V		2.3 V	
2.4 V		2.5 V	
2.6 V		2.7 V	
2.8 V		2.9 V	
3.0 V		3.1 V	
3.2 V		3.27 V	
*3.3 V		3.45 V	

* default setting

Note: Please refer to the voltage that is shown on the processor chip.

1.8.3 Watchdog timer configuration (JP4)

An on-board watchdog timer reduces the chance of disruptions which EMP (electro-magnetic pulse) interference can cause. This is an invaluable protective device for standalone or unmanned applications. Setup involves two jumpers and running the control software. (Refer to Appendix A.)

Watchdog timer action (JP4)

When the watchdog timer activates (CPU processing has come to a halt), it can reset the system. This can be set via setting JP4 as shown below:

Table 1-7: Watchdog timer system reset select (JP4)

*System Reset	
JP4	

* default setting

1.8.4 COM2 settings for RS-232/422/485 (JP8)















Table 1-8: COM2 settings for RS-232/422/485 (JP8)

Pins closed	*RS-232	RS-422	RS-485
1 - 2	on	off	off
3 - 4	off	on	off
5 - 6	off	off	on
7 - 8	off	on	on
7 - 9	on	-	-
10 - 12	-	on	on
11 - 12	on	-	-
13 - 14	-	on	-
13 - 15	on	-	-
16 - 18	-	on	-
17 - 18	on	-	-

* default setting

1.8.5 DOC2000 address setting (JP7)

Table 1-9: DOC2000 address setting (JP7)



Address	JP7	Address	JP7
*OFF	2  1 	CC00 ~ CDFF	2  1 
D800 ~ D9FF	2  1 	DC00 ~ DDFF	2  1 
D000 ~ D1FF	2  1 	D400 ~ D5FF	2  1 
E000 ~ E1FF	2  1 		

* default setting

1.8.6 CMOS backup select (JP5)

Warning: To avoid damaging the computer, always turn off the power supply before setting "Clear CMOS". Set the jumper back to "3.0 V Battery On" before turning on the power supply.



Table 1-10: RTC power and CMOS clear (JP5)

	*Normal	CMOS data clear
JP5		

* default setting

1.8.7 DLL circuit for CPU clock optimization (JP10)

Table 1-11: DLL circuit for CPU clock optimization (JP10)

	Disable	*Enable
JP10		

1.8.8 Buzzer enable/disable (CN16)

Table 1-12: Buzzer enable/disable (CN16)

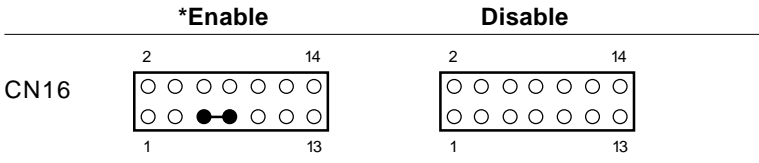

* default setting

1.9 Installing DRAM (SIMMs)

You can install anywhere from 8 to 128 MB of DRAM into your PCA-6154/6154L. The card provides **two** 72-pin SIMM (Single In-line Memory Module) sockets. Each socket accepts 4, 8, 16, 32 or 64 MB SIMMs. DRAM access time ≤ 60 ns.

Note: For higher system stability two SIMM should be installed when operating the PCA-6154/PCA-6154L

1.9.1 Installing SIMMs

NOTE: *The modules can only fit into a socket one way. Their gold pins must point down into the SIMM socket.*

The procedure for installing SIMMs appears below. Please follow these steps carefully.

1. Ensure that all power supplies to the system are switched Off.
2. Install the SIMM card. Install the SIMM so that its gold pins point down into the SIMM socket.
3. Slip the SIMM into the socket at a 45 degree angle and carefully fit the bottom of the card against the connectors.
4. Gently push the SIMM into a perpendicular position until the clips on the ends of the SIMM sockets snap into place.
5. Check to ensure that the SIMM is correctly seated and all connector contacts touch. The SIMM should not move around in its socket.

CHAPTER 2

Connecting Peripherals

This chapter tells how to connect peripherals, switches and indicators to the PCA-6154/6154L board. You can access most of the connectors from the top of the board while it is installed in the chassis. If you have a number of cards installed, or your chassis is very tight, you may need to partially remove the card to make all the connections.

The following table lists the connectors on the PCA-6154/6154L.

Table 2-1: Connectors

Number	Function
CN1	IDE connector
CN2	FDD connector
CN3	Parallel port connector
CN4	CPU fan power connector
CN5	IR connector
CN6	Main power connector
CN7	VGA connector
CN8	Ethernet RJ-45A connector
CN9	USB connector
CN10	COM2 connector
CN11	COM1 connector
CN12	PC/104 Con. A, B
CN13	PC/104 Con. C, D
CN14	External keyboard connector
CN15	Keyboard and PS/2 mouse connector
CN16	Front panel connector
CN17	HDD LED

The following sections tell how to make each connection. In most cases, you will simply need to connect a standard cable. All of the connector pin assignments are shown in Appendix C.

Warning!



Always completely disconnect the power cord from your chassis whenever you are working on it. Do not make connections while the power is on. Sensitive electronic components can be damaged by a sudden rush of power. Only experienced electronics personnel should open the PC chassis.

Caution! *Always ground yourself to remove any static charge before touching the CPU card. Modern electronic devices are very sensitive to static electric charges. Use a grounding wrist strap at all times. Place all electronic components on a static-dissipative surface or in a static-shielded bag when they are not in the chassis.*



2.1 Enhanced IDE Connector (CN1)

You can attach two IDE (Integrated Device Electronics) drives to the PCA-6154/6154L's internal controller. The PCA-6154/6154L CPU card has an EIDE connector, CN1.

Wire number 1 on the cable is red or blue, the other wires are gray. Connect one end to connector CN1 on the CPU card. Make sure that the red (or blue) wire corresponds to pin 1 on the connector (on the right side). See Chapter 1 for help finding the connector.

Unlike floppy drives, IDE hard drives can connect in either position on the cable. If you install two drives, you will need to set one as the master and one as the slave. You do this by setting the jumpers on the drives. If you use just one drive, you should set it as the master. See the documentation that came with your drive for more information.

Connect the first hard drive to the other end of the cable. Wire 1 on the cable should also connect to pin 1 on the hard drive connector, which is labeled on the drive circuit board. Check the documentation that came with the drive for more information.

Connect the second drive as described above on CN1.

Note: *We don't recommend connecting to a Seagate ST-31010A, ST-31011A, ST-1277A, ST-31720A, ST-31721A, ST-32120A, ST-32121A, ST-32531A, 33230A, ST-33240A, ST-34340A, or ST-3852A IDE HDD. This is an incompatibility issue and not a fault of either device.*

2.2 VGA Display Connector (CN7)

The PCA-6154/6154L provides a VGA controller for a high resolution VGA interface. The PCA-6154/6154L's CN7 is a DB-15 connector for VGA monitor input. Pin assignments for the CRT display are detailed in Appendix D. Share memory architecture supports 0.5 MB, 1 MB, 1.5 MB, 2 MB, 2.5 MB, 3 MB, 3.5 MB and 4 MB system memory. The memory is configured in the system BIOS setup.

2.3 Floppy Drive Connector (CN2)

You can attach up to two floppy disk drives to the PCA-6154/6154L's on-board controller. You can use any combination of 5.25" (360 KB/1.2 MB) and/or 3.5" (720 KB/1.44/2.88 MB) drives.

The card comes with a 34-pin daisy-chain drive connector cable. On one end of the cable is a 34-pin flat-cable connector. On the other end are two sets of floppy disk drive connectors. Each set consists of a 34-pin flat-cable connector (usually used for 3.5" drives) and a printed-circuit-board connector (usually used for 5.25" drives). You can use only one connector in each set. The set on the end (after the twist in the cable) connects to the A: floppy. The set in the middle connects to the B: floppy.

2.4 Parallel Port Connector (CN3)

The parallel port is normally used to connect the CPU card to a printer. The PCA-6154/6154L includes an on-board parallel port, accessed through a 26-pin flat-cable connector, CN3. The card comes with an adapter cable which lets you use a traditional DB-25 connector. The cable has a 26-pin connector on one end and a DB-25 connector on the other, mounted on a retaining bracket. The bracket installs at the end of an empty slot in your chassis, giving you access to the connector.

The parallel port is designated as LPT1 and can be disabled or changed to LPT2 or LPT3 in the system BIOS setup.

To install the bracket, find an empty slot in your chassis. Unscrew the plate that covers the end of the slot. Screw in the bracket in place of the plate. Next, attach the flat-cable connector to CN3 on the CPU card. Wire 1 of the cable is red or blue, and the other wires are gray. Make sure that wire 1 corresponds to pin 1 of CN3. Pin 1 is on the right side of CN3.

2.5 Keyboard & PS/2 Mouse Connector (CN15)

The PCA-6154/6154L board provides a keyboard connector. A 6-pin mini-DIN connector (CN15) on the card mounting bracket supports single-board computer applications. The card comes with an adapter to convert from the 6-pin mini-DIN connector to a standard DIN connector and to a PS/2 mouse connector.

2.6 Front Panel Connector (CN16)

Next, you may want to install external switches to monitor and control the PCA-6154/6154L. These features are optional - install them only if you need them. The front panel connector (CN16) is a 14-pin male, dual in-line header and provides connections for a speaker, hard disk access indicator, power on indicator, turbo indicator and an input switch for resetting the card.

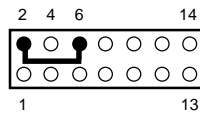

LED interface

The front panel LED indicator for power on is an active high signal.

Reset switch

If you install a reset switch, it should be a open single pole switch. Momentarily pressing the switch will activate a reset. The switch should be rated for 10 mA, 5 V.

If you need to make your own cable, you can find the pin assignments for the card's connector in Appendix C.

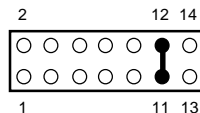

2.7 Hard Disk Drive LED (CN17)

You can connect a LED to connector CN17 to indicate when the HDD is active. Marks on the circuit board indicate LED polarity.

2.8 Serial Ports (CN11: COM1; CN10: COM2)

The PCA-6154/6154L offers two serial ports: COM1 in RS-232, COM2 in RS-232/422/485. These ports let you connect to serial devices (a mouse, printers, etc.) or a communication network.

You can select the address for each port (For example,3F8H [COM1], 2F8H [COM2]) or disable it, using the BIOS Advanced Setup program, covered in Chapter 4.

The card mounting bracket holds the serial port connector for the one port, and the parallel port and serial port adapter kit (supplied with the card) holds the connector for the other port. This lets you connect and disconnect cables after you install the card. The DB-9 connector on the bottom of the bracket is the first RS-232 port, COM1. The DB-9 connector on the adapter kit is the second serial port, COM2.

Table 2-2: Serial port connections (COM1, COM2)

Connector	Function
COM1	RS-232
COM2	RS-232/422/485

2.8.1 RS-232 connection (COM1-CN11)

Different devices implement the RS-232 standard in different ways. If you are having problems with a serial device, be sure to check the pin assignments for the connector.

2.8.2 RS-232/422/485 connection (COM2-CN10)

COM2 is an RS-232/422/485 serial port. The specific port type is determined by jumper settings, as detailed in Chapter 1.

The IRQ and address range for both ports are fixed. However, if you wish to disable the port or change these parameters later, you can do this in the system BIOS setup. The table below shows the settings for the PCA-6154/6154L board's ports:

Table 2-3: PCA-6154/6154L serial port default settings

Port	Address	Interrupt	Default
COM1	3F8, 3E8	IRQ4	3F8
COM2	2F8, 2E8	IRQ3	2F8

2.9 Power Connectors

2.9.1 Main power connector +5 V, -12 V, +12 V (CN6)

If you prefer not to acquire power through PCA-6154/6154L's backplane via the gold H-connectors, CN6 also provides power input connectors for +5 V, -12 V and +12 V. Pin 8 of the PS/2 power supply can be used, too.

2.9.2 CPU fan power supply connector (CN4)

This provides power supply to the optional CPU cooling fan. This connector is only available when +5 V, -12 V and +12 V power is supplied to the board.

Warning! *Before making the connection, make sure the voltage is absolutely correct and matched with the correct connector.*

2.10 Ethernet Configuration (PCA-6154 Only)

The PCA-6154 is equipped with a high performance 32-bit PCI-bus Fast Ethernet interface which is fully compliant with IEEE 802.3u 100/10Base-T specifications. It is supported by all major network operating systems and is 100% Novell NE-2000 compatible.

The medium type can be configured via the RSET8139.EXE program included on the utility disk. (See Chapter 3 for detailed information.)

RJ-45A connector (CN8)

100/10BASE-T connects to the PCA-6154 via an adapter cable to the RJ-45 standard jack.

Network boot

The Network Boot feature is built into the BIOS. It can be enabled/disabled in the chipset setup of the CMOS configuration. Refer to "BIOS Setting" in Chapter 4 for more information.

2.11 USB Connector (CN9)

The PCA-6154/6154L board provides two USB (Universal Serial Bus) interfaces, which give complete plug and play, hot attach/detach for up to 127 external devices. The USB interfaces comply with USB specification rev. 1.0 and are fuse protected.

The USB interfaces are accessed through a 10-pin flat-cable connector, CN9. The adapter cable has a 10-pin connector on one end and a USB connector on the bracket.

The USB interfaces can be disabled in the system BIOS setup.

2.12 IR Connector (CN5)

This connector supports the optional wireless infrared transmitting and receiving module. This module mounts on the system case. You must configure the setting through BIOS setup.

CHAPTER 3

VGA Display & Ethernet Software Configuration

This chapter details the software configuration information. It shows you how to configure the board to match your application requirements. AWARD System BIOS is covered in Chapter 4.

Sections include:

- VGA display configuration
- Ethernet interface configuration

3.1 Introduction

The PCA-6154/6154L system BIOS and custom drivers are located in a 256 Kbyte, 32-pin (JEDEC spec.) Flash ROM device, designated U11. A single Flash chip holds the system BIOS, VGA BIOS, and Back-up CMOS Data. The display can be configured via software. This method minimizes the number of chips and eases configuration. You can change the display BIOS simply by reprogramming the Flash chip.

3.2 Utility Disk

The PCA-6154/6154L is supplied with a software utility disk that holds the necessary file for setting up the VGA display and Ethernet and Windows controller. The disks' definition is as follows:

- Disk 1: VGA/LCD utility for Windows NT
- Disk 2: VGA/LCD utility for Windows 3.1 English version
- Disk 3: VGA/LCD utility for OS2 3.0 #1
- Disk 4: VGA/LCD utility for OS2 3.0 #2
- Disk 5: LAN driver #1 (PCA-6154 only)
- Disk 6: LAN driver #2(PCA-6154 only)
- Disk 7: IDE driver
- Disk 8: VGA/LCD utility for Windows 95
- Disk 9: VGA/LCD utility for Windows 3.1 Chinese version
- Total: 9 disks

3.3 VGA Display Software Configuration

The PCA-6154/6154L's on-board VGA interface supports traditional analog CRT monitors. The VGA controller is built into the system's chip (SIS5598). It can support 1 to 4 MB of video memory share with the system memory. The interface can drive CRT displays with resolutions up to 1024 x 768 in 256 colors at 1 MB share memory, and up to 1280 x 1024 in 64 K colors at 4 MB share memory. The VGA interface is configured completely via the software utility, so you do not have to set any jumpers.

3.4 Ethernet Software Configuration (PCA-6154 only)

The PCA-6154's on-board Ethernet interface supports all major network operating systems. To configure the medium type, to view the current configuration, or to run diagnostics:

1. Power the PCA-6154 on. Ensure that the RSET8139.EXE file is located in the working drive (Disk 5 & 6, LAN driver).
2. At the prompt type RSET8139.EXE and press <Enter>. The Ethernet configuration program will then be displayed.
3. This simple screen shows all the available options for the Ethernet interface. Just highlight the option you wish to change by using the Up and Down keys. To change a selected item, press <Enter>, and a screen will appear with the available options. Highlight your option and press <Enter>. Each highlighted option has a helpful message guide displayed at the bottom of the screen for additional information.
4. After you have made your selections and are certain it is the

configuration that you want, press ESC. A prompt will appear asking if you want to save the configuration. Press Y if you want to save.

The Ethernet Setup Menu also offers three very useful diagnostic functions:

1. Run EEPROM test.
2. Run Diagnostics on Board.
3. Run Diagnostics on Network.

Each option has its own display screen which shows the format and result of any diagnostic tests undertaken.

CHAPTER 4

Award BIOS Setup

This chapter describes how to set the card's BIOS configuration data.

4.1 AWARD BIOS Setup

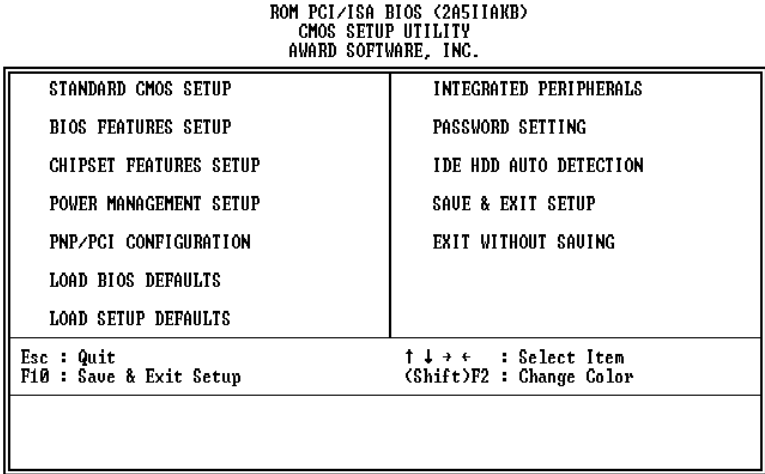

Figure 4-1: Setup program initial screen

Award’s BIOS ROM has a built-in Setup program that allows users to modify the basic system configuration. This type of information is stored in battery-backed RAM so that it retains the Setup information when the power is turned off.

4.1.1 Entering setup

Turning on the computer and pressing immediately will allow you to enter Setup.

4.1.2 Standard CMOS setup

Choose the “STANDARD CMOS SETUP” option from the INITIAL SETUP SCREEN Menu, and the screen below is displayed. This standard Setup Menu allows users to configure system components such as date, time, hard disk drive, floppy drive, display, and memory.

ROM PCI/ISA BIOS (2A5IIAKB)
CMOS SETUP UTILITY
AWARD SOFTWARE, INC.

Date <mm:dd:yy> : Mon. Oct 7 1996		
Time <hh:mm:ss> : 16 : 52 : 38		
HARD DISKS	TYPE SIZE CYLS HEAD PRECOMP LANDZ SECTOR MODE	
Primary Master	:Auto 0 0 0 0 0 0 Auto	
Primary Slave	:None 0 0 0 0 0 0 -----	
Drive A: 1.44M. 3.5 in.		
Drive B: None		
Video: EGA/VGA		
Halt On: All Errors		
Base Memory: 640K		
Extended Memory: 15360K		
Other Memory: 384K		
Total Memory: 16384K		
ESC: Quit	↑↓←→: Select Item	PU/PD/+/-: Modify
F1: Help	<Shift> F2: Change Color	

Figure 4-2: CMOS setup screen

4.1.3 BIOS features setup

The “BIOS FEATURES SETUP” screen appears when choosing the BIOS FEATURES SETUP item from the CMOS SETUP UTILITY Menu. It allows the user to configure the PCA-6154/6154L according to his particular requirements.

Below are some major items that are provided in the BIOS FEATURES SETUP screen:

ROM PCI/ISA BIOS (2A5IIAKB)
 CMOS SETUP UTILITY
 AWARD SOFTWARE, INC.

Virus Warning : Disabled CPU Internal Cache : Enabled External Cache : Enabled Quick Power On Self Test : Enabled Boot Sequence : C, A Swap Floppy Drive : Disabled Boot Up Floppy Seek : Enabled Boot Up NumLock Status : On Boot Up System Speed : High Gate A20 Option : Fast Memory Parity Check : Disabled Typematic Rate Setting : Disabled Typematic Rate (Char/sec): 6 Typematic Delay (Msec) : 250 Security Option : Setup PCI/VGA Palette Snoop : Disabled OS Select for DRAM >64M : Non-OS2	Video Bios Shadow : Enabled C8000-CBFFF Shadow : Disabled CC000-CFFFF Shadow : Disabled D0000-D3FFF Shadow : Disabled D4000-D7FFF Shadow : Disabled D8000-DBFFF Shadow : Disabled DC000-DFFFF Shadow : Disabled
Esc : Quit ↑↓→← : Select Item F1 : Help PU/PD+/- : Modify F5 : Old Values <Shift>F2 : Color F6 : Load BIOS Defaults F7 : Load Setup Defaults	

Figure 4-3: BIOS features setup screen

Virus Warning

During and after the system boots up, any attempt to write to the boot sector or partition table of the hard disk drive will halt the system. In this case, a warning message will be displayed. You can run the anti-virus program to locate the problem.

If Virus Warning is Disabled, no warning message will appear if anything attempts to access the boot sector or hard disk partition.

CPU Internal Cache/External Cache

Depending on the CPU/chipset design, these options can speed up memory access when enabled.

Quick Power On Self Test

This option speeds up the Power-On Self Test (POST) conducted as soon as the computer is turned on. When enabled, BIOS shortens or skips some of the items during the test. When disabled, normal POST procedures assumes.

Boot Sequence

This function determines the sequence in which the computer will search the drives for the disk operating system (i.e. DOS). The default value is "C, A".

A,C	System will first search the FDD, then the HDD.
C,A	System will first search the HDD, then the FDD.
C only	System will only search the HDD.

Boot Up Floppy Seek

During POST, BIOS will determine if the floppy disk drive installed is 40 or 80 tracks. 360 KB type is 40 tracks while 720 KB, 1.2 MB, and 1.44 MB are all 80 tracks.

Enabled	BIOS searches the floppy drive to determine if it is 40 or 80 tracks. Note that BIOS cannot differentiate 720 KB, 1.2 MB, and 1.44 MB type drives as they are all 80 tracks.
---------	--

Disabled	BIOS will not search for the floppy drive type by track number. Note that there will not be any warning message if the drive installed is 360 KB.
----------	---

Boot Up NumLock Status

The default is “On”.

On	Keypad boots up to number keys.
----	---------------------------------

Off	Keypad boots up to arrow keys.
-----	--------------------------------

Boot Up System Speed

High	Sets the speed to high
------	------------------------

Low	Sets the speed to low
-----	-----------------------

IDE HDD Block Mode

Enabled	Enable IDE HDD Block Mode. BIOS will detect the block size of the HDD and send a block command automatically.
---------	---

Disabled	Disable IDE HDD Block Mode
----------	----------------------------

Gate A20 option

Normal	The A20 signal is controlled by the keyboard controller or chipset hardware
--------	---

Fast	Default: Fast. The A20 signal is controlled by Port 92 or chipset specific method.
------	--

Typematic Rate Setting

The typematic rate determines the characters per second accepted by the computer. Typematic Rate setting enables or disables the typematic rate.

Typematic Rate (Char/Sec)

BIOS accepts the following input values (character/second) for Typematic Rate: 6, 8, 10, 12, 15, 20, 24, 30.

Typematic Delay (msec)

When holding down a key, the Typematic Delay is the time interval between the appearance of the first and second characters. The input values (msec) for this category are: 250, 500, 750, 1000.

Security Option

This setting determines whether the system will boot if the password is denied, while limiting access to Setup.

System	The system will not boot, and access to Setup will be denied if the correct password is not entered at the prompt.
Setup	The system will boot, but access to Setup will be denied if the correct password is not entered at the prompt.

Note: To disable security, select PASSWORD SETTING in the main menu. At this point, you will be asked to enter a password. Simply hit the <ENTER> key to disable security. When security is disabled, the system will boot, and you can enter Setup freely.

OS Select for DRAM>64 MB

This setting is under OS/2 system.

Video BIOS Shadow

This determines whether video BIOS will be copied to RAM, which is optional according to the chipset design. When enabled, Video Shadow increases the video speed.

C8000 - CFFFF Shadow/DC000-DFFFF Shadow

These determine whether optional ROM will be copied to RAM in blocks of 16 KB.

Enabled	Optional shadow is enabled
Disabled	Optional shadow is disabled

4.1.4 CHIPSET features setup

By choosing the “CHIPSET FEATURES SETUP” option from the INITIAL SETUP SCREEN Menu, the screen below is displayed. This sample screen contains the manufacturer’s default values for the PCA-6154/6154L.

ROM PCI/ISA BIOS (2A5IIAKB)
CHIPSET FEATURES SETUP
AWARD SOFTWARE, INC.

Auto Configuration : Enabled	CPU-PCI Burst Mem.WR : Disabled
L2 (WB) Tag Bit Length : 8 bits	ISA Bus Clock Frequency: 7.159 MHz
SRAM Back to Back : Enabled	System BIOS Cacheable : Enabled
NA # Enable : Enabled	Video BIOS Cacheable : Enabled
Starting Point of Paging : 1T	Memory Hole at 15M-16M : Disabled
Refresh Cycle Time (US) : 15.6	VGA Shared Memory Size: 1 MB
RAS Pulse Width Refresh : 4T	VGA Mem Clock (MHz) : 55
RAS Precharge Time : 2T	Linear Mode SRAM Support: Disabled
RAS to CAS Delay : 2T	
CAS # Pulse Width (FP) : 2T	
CAS # Pulse Width (EDO) : 1T	
RAMW# Assertion Timing : 3T	
CAS Precharge Time (FP) : 1T/2T	
CAS Precharge Time (EDO): 1T/2T	
Enhanced Memory Write : Disabled	Esc : Quit ↑↓→←: Select Item
Read Prefetch Memory RD: Enabled	F1 : Help PU/PD+/- : Modify
CPU to PCI Post Write : 4T	F5 : Old Values <Shift>F2 : Color
	F6 : Load BIOS Defaults
	F7 : Load Setup Defaults

Figure 4-4: CHIPSET features setup screen

VGA Shared Memory Size

Share memory architecture can support 0.5 MB, 1MB, 1.5 MB, 2 MB, 3 MB, 3.5 MB and 4 MB of system memory.

4.1.5 Power management setup

The power management setup controls the CPU cards' "green" features. The following screen shows the manufacturer's default.

ROM PCI/ISA BIOS (2A5IIAKB)
CMOS SETUP UTILITY
AWARD SOFTWARE, INC.

Power Management	: Disable	VGA Activity	: Disable
PM Control by APM	: Yes	IRQ3 (COM2)	: Enable
Video Off Option	: Susp,Stby → Off	IRQ4 (COM1)	: Enable
Video Off Meethod	: V/H SYNC+Blank	IRQ5 (LPT2)	: Enable
Switch Function	: Break/Wake	IRQ6 (Floppy Disk)	: Enable
Doze Speed (div by)	: 2	IRQ7 (LPT1)	: Enable
Stdby Speed (div by)	: 3	IRQ8 (RTC Alarm)	: Disable
Modem Use IRQ	: 3	IRQ9 (IRQ2 Redir)	: Enable
Hot Key Power Off	: Disabled	IRQ10 (Reserved)	: Enable
PM Timers		IRQ11 (Reserved)	: Enable
HDD Off After	: Disable	IRQ12 (PS/2 Mouse)	: Enable
Doze Mode	: Disable	IRQ13 (Coprocessor)	: Enable
Standby Mode	: Disable	IRQ14 (Hard Disk)	: Enable
Suspend Mode	: Disable	IRQ15 (Reserved)	: Enable
PM Events			
COM Ports Activity	: Enable	Esc : Quit	↑↓←→ : Select Item
LPT Ports Activity	: Enable	F1 : Help	PU/PD/+/- : Modify
HDD Ports Activity	: Enable	F5 : Old Values <Shift>F2	: Color
		F6 : Load BIOS Defaults	
		F7 : Load Setup Defaults	

Figure 4-5: Power management setup screen

Power Management

This option allows you to determine if the values in power management are disabled, user-defined, or predefined.

HDD Power Management

You can choose to turn the HDD off after a one of the time interval listed, or when the system is in Suspend mode. If in a power saving mode, any access to the HDD will wake it up.

Note: HDD will not power down if the Power Management option is disabled.

IRQ Activity

IRQ can be set independently. Activity on any enabled IRQ will wake up the system.

4.1.6 PCI configuration setup

ROM PCI/ISA BIOS (2A5IIAKB)
CMOS SETUP UTILITY
AWARD SOFTWARE, INC.

Resources Controlled By : Manual Reset Config. Data : Disabled	PCI IRQ Activated By : Level PCI IDE 2nd Channel : Enabled PCI IDE IRQ Map To : PCI-AUTO Primary IDE INT# : A Secondary IDE INT# : B
IRQ-3 assigned to : Legacy ISA IRQ-4 assigned to : Legacy ISA IRQ-5 assigned to : PCI/ISA PnP IRQ-7 assigned to : Legacy ISA IRQ-9 assigned to : PCI/ISA PnP IRQ-10 assigned to : PCI/ISA PnP IRQ-11 assigned to : PCI/ISA PnP IRQ-12 assigned to : PCI/ISA PnP IRQ-14 assigned to : Legacy ISA IRQ-15 assigned to : Legacy ISA DMA-0 assigned to : PCI/ISA PnP DMA-1 assigned to : PCI/ISA PnP DMA-3 assigned to : PCI/ISA PnP DMA-5 assigned to : PCI/ISA PnP DMA-6 assigned to : PCI/ISA PnP DMA-7 assigned to : PCI/ISA PnP	Esc : Quit ↑↓←→: Select Item F1 : Help PU/PD/+/- : Modify F5 : Old Values <Shift>F2 : Color F6 : Load BIOS Defaults F7 : Load Setup Default

Figure 4-6: PCI configuration screen

4.1.7 Load BIOS defaults

“LOAD BIOS DEFAULTS” indicates the most appropriate values for the system parameters for minimum performance. These default values are loaded automatically if the stored record created by the Setup program becomes corrupted (and therefore unusable).

4.1.8 Load setup defaults

“LOAD SETUP DEFAULTS” loads the values required by the system for maximum performance.

4.1.9 Integrated Peripherals

ROM PCI/ISA BIOS (2A5IIAKB)
CMOS SETUP UTILITY
AWARD SOFTWARE, INC.

Internal PC/IDE : Primary	PS/2 mouse function : Disabled
IDE Primary Master PIO : Auto	Ethernet Boot ROM : Disabled
IDE Primary Slave PIO : Auto	USB Controller : Disabled
Primary Master Ultra DMA : Auto	
Primary Slaver Ultra DMA : Auto	
IDE Burst Mode : Disabled	
IDE Data Port Post Write : Enabled	
IDE HDD Block Mode : Enabled	
Onboard FDC Controller : Enabled	
Onboard Serial Port 1 : 3F8/IRQ4	
Onboard Serial Port 2 : 2F8/IRQ3	
IR Address Select : Disable	
Onboard Parallel Port : 378/IRQ7	Esc : Quit ↑↓←→: Select Item
Onboard Parallel Mode : ECP+EPP	F1 : Help PU/PD/+/- : Modify
ECP Mode Use DMA : 3	F5 : Old Values <Shift>F2 : Color
	F6 : Load BIOS Defaults
	F7 : Load Setup Default

Figure 4-7: Integrated peripherals

Note: If you enable the IDE HDD block mode, the enhanced IDE driver will be enabled.

4.1.10 Password setting

To change, confirm, or disable the password, choose the “PASSWORD SETTING” option from the Setup main menu and press [Enter]. The password can be at most 8 characters long.

Remember, to enable this feature. You must first select the Security Option in the BIOS FEATURES SETUP to be either “Setup” or “System.” Pressing [Enter] again without typing any characters can disable the password setting function.

4.1.11 IDE HDD auto detection

“IDE HDD AUTO DETECTION” automatically self-detect for the correct hard disk type.

4.1.12 Save & exit setup

If you select this and press the [Enter] key, the values entered in the setup utilities will be recorded in the CMOS memory of the chipset. The microprocessor will check this every time you turn your system on and compare this to what it finds as it checks the system. This record is required for the system to operate.

4.1.13 Exit without saving

Selecting this option and pressing the [Enter] key lets you exit the Setup program without recording any new values or changing old ones.

CHAPTER 5

PCI SVGA Setup

The PCA-6154/6154L features an on-board VGA interface. This chapter provides instructions for installing and operating the software drivers on the included display driver diskette.

5.1 Before you begin

To facilitate the installation of the enhanced display device drivers and utility software, you should read the instructions in this chapter carefully before you attempt installation. The enhanced display drivers for the PCA-6154/6154L board are located on the software installation diskette. You must install the drivers and utility software by using the supplied SETUP program for DOS drivers.

Note: *The files on the software installation diskette are compressed. Do not attempt to install the drivers by copying the files manually. You must use the supplied SETUP program to install the drivers.*

Before you begin, it is important to note that most display drivers need to have the relevant software application already installed in the system prior to installing the enhanced display drivers. In addition, many of the installation procedures assume that you are familiar with both the relevant software applications and operating system commands. Review the relevant operating system commands and the pertinent sections of your application software's user's manual before performing the installation.

5.2 Installation

- Disk 1: Windows NT driver
- Disk 2: Windows 3.1, Windows 95 drivers
- Disk 3: OS2 3.0 driver #1
- Disk 4: OS2 3.0 driver #2

5.3 Driver installation

Necessary prerequisites

The instructions in this manual assume that you understand elementary concepts of MS-DOS and the IBM Personal Computer. Before you attempt to install any driver or utility you should: know how to copy files from a floppy disk to a directory on the hard disk, understand the MS-DOS directory structure, and know how to format a floppy disk. If you are uncertain about any of these concepts, please refer to the DOS or Windows user reference guides for more information before you proceed with the installation.

Before you begin

Before you begin installing software drivers, you should make a backup copy of the display driver diskette and store the original in a safe place. The display driver diskette contains drivers for several versions of certain applications. You must install the correct version in order for the driver to work properly, so make sure you know which version of the application you have.

5.3.1 Windows setup

These drivers are designed to work with Microsoft Windows 3.1. You may install these drivers through Windows or in DOS.

Step 1: Install Windows as you normally would for a VGA display. Run Windows to make sure that it is working correctly.

Step 2: Place the display driver diskette in drive A. In Windows Program Manager, choose *File* from the Options Menu. Then from the pull-down menu, choose *Run . . .*. At the command line prompt, type **A:\WINSETUP**. Press the <ENTER> key or click *OK* to begin the installation. At this point the setup program locates the directory where Windows is installed. For proper operation, the drivers must be installed in the Windows subdirectory. Press <ENTER> to complete the installation. Once completed, the Display Driver Control Panel appears on the screen. This Control Panel allows you to select and load the installed drivers.

Another method of installing these drivers is through the File Manager. Click on **Drive A:**. Then double-click on **WINSETUP.EXE** to begin installation.

Changing Display Drivers in Windows

To change display drivers in Windows, select the **Windows Setup** icon from the Main window. You will be shown the current setup configuration. Select **Change System Settings** from the Option menu. Click on the arrow at the end of the Display line. You will be shown a list of display drivers. Click on the driver you want. Then click on the **OK** button. Follow the directions to complete the setup.

Changing Color Schemes

After you change display drivers, you may notice that the color scheme used by Windows looks strange. This is because different drivers have different default colors. To change the color scheme, select the **Control Panel** from the Main window. Select the **Color** icon. You will be shown the current color scheme. Choose a new color scheme and click the **OK** button.

5.3.2 DOS Setup

Step 1: Install Windows as you normally would for a VGA display. Run Windows to make sure that it is working correctly. Then exit Windows.

Step 2: Place the display driver diskette in drive A. Type **A:** <ENTER> to make this the default drive. Type **SETUP** <ENTER> to run the driver SETUP program. Press any key to get to the applications list. Using the arrow keys, select **Windows Version 3.1** and press the <ENTER> key. Press the <ENTER> key to select **All Resolutions**, and then press <END> to begin the installation. At this point you will be asked for the path to your Windows System directory (default C:\WINDOWS). When the installation is complete, press any key to continue. Press <ESC> followed by Y to exit to DOS.

Step 3: Change to the directory where you installed Windows (usually C:\WINDOWS).

Step 4: Type **SETUP** <ENTER> to run the Windows Setup program. It will show the current Windows configuration. Use the up arrow key to move to the Display line and press <ENTER>. A list of display drivers will be shown. Use the arrow keys to select one of the drivers starting with an asterisk (*) and press <ENTER>.

Step 5: Follow the directions on the screen to complete the setup. In most cases, you may press <ENTER> to accept the suggested option. When Setup is done, it will return to DOS. Type **WIN** <ENTER> to start Windows with the new display driver.

Changing Display Drivers in DOS

To change display drivers from DOS, change to the Windows directory and run Setup, repeating steps 4 and 5 from the previous page. Besides the special display drivers marked by an asterisk (*), you should be able to use the following standard drivers:

VGA	640x480, 16 colors
Super VGA	800x600, 16 colors

Panning Drivers

Special panning drivers are provided to allow high-resolution modes to be displayed on a flat panel or CRT. These drivers will show a section of a larger screen and will automatically pan, or scroll, the screen horizontally and vertically when the mouse reaches the edge of the display.

Linear Acceleration Drivers

A special high-performance linear acceleration driver is provided for 256-color modes. This driver may require special hardware and may not be supported on all systems. It is only available for Windows 3.1.

5.4 Windows 95 Drivers Setup Procedure

1. Boot system with VGA or SuperVGA driver.
2. Select properties from a menu after right button press.
3. Select Display.
4. Select Change Display.
5. Select Change Monitor.
6. Select Change Adapter.
7. Select Have Disk.

5.5 Windows NT Drivers Setup Procedure

Step 1

1. Install Windows NT as you normally would for a VGA display.
2. First click the Start button, choose Settings and click on the Control Panel.
3. Choose the Display icon and click on the icon.
4. In the Display Properties window, click on the Settings tab.
5. Click on Change Display Type. In the Change Display Type window, click on the Change button under Adapter Type. This will bring up the Select Device window.

Step 2

1. In the Select Device window, click on the Other button. Enter source directory where the Windows NT driver files are located.
2. Press <ENTER> and the name of the Chips and Technologies Video Accelerator driver will appear at the end of Models list box. Scroll to the end of the list box and double click on the driver.
3. Once the installation is complete, the system must be shut down and restarted.

Step 3

1. Upon restarting your computer, select the desired display settings from the Display Property dialog box.
2. Click on Test to test the newly selected graphics mode. A color test screen should appear, followed by the Testing Mode window.
3. Click on Yes to continue. The Display Settings Change window will appear.
4. Click on Restart Now for the new settings to take effect.

5.6 OS/2 Drivers Setup Procedure

Preliminary Steps

The following steps must be performed before you install the SIS5598 display driver:

1. OS/2 DOS Support must be installed.
2. If you previously installed SVGA support, you must reset the system to VGA mode. VGA is the default video mode enabled when OS/2 is installed.

To restore VGA mode, use Selective Install and select VGA for Primary Display. For more information on this procedure, see the section on Changing Display Adapter Support in the OS/2 User's Guide.

Installing from Diskette

To install this driver:

1. Open an OS/2 full screen or windowed session.
2. Place the SIS5598 Display Driver Diskette in Drive A.
3. At the OS/2 command prompt, type the following commands to copy the files to the OS/2 drive:

A: <ENTER> to make this the default drive.

SETUP A: C: <ENTER>

where A: is the floppy disk drive, and

C: is the hard disk partition containing \OS2

When the setup program is completed, you will need to perform a shutdown and then restart the system in order for changes to take effect.

A log of the information output during the install can be found in
<root>:\OS2\INSTALL\DISPLAY.LOG

4. After restarting the system:

- a) Open the OS/2 System folder.
- b) Open the System Setup folder.
- c) Open the Display Driver Install Object.

Steps a), b) and c) will execute the Display Driver Installation (DSPINSTL) utility program to finish installation of the new drivers.

- d) When the Display Driver Install window appears, select Primary Display and then select OK.
- e) When the Primary Display Driver List window appears, select "Chips and Technologies 65550/554" from the list of adapter types. Then select OK to install the video driver.
- f) When the installation is complete, you will need to shut down and then restart the system for the changes to take effect. Make sure you remove the install diskette before restarting the system.

When the system has restarted, the display driver will be initialized for 640 x 480 x 256 color, 60 Hz refresh. To switch to a different video resolution color depth or a different refresh rate, see the following sections.

Selecting Monitor Type

Monitor type is initially set to DEFAULT. This DEFAULT setting may not allow you to select all resolution/refresh combinations that are available for your monitor. The following steps can be done to select monitor type. This section applies only after installation, or when a different monitor is used.

1. Open the OS/2 System folder.
2. Open the System Setup folder.
3. Open the System object.
4. When the System-Settings notebook appears, select the Screen tab. This will take you to page 2 of the settings.
5. On Screen page 2, select your monitor type from the Display Name list. If your monitor is not listed, select DEFAULT.

It may be necessary to restart your system to have all refresh rate options available.

Selecting Screen Resolution/Refresh Rate

To switch to a different video resolution, color depth or refresh rate, follow the steps below.

1. Open the OS/2 System folder.
2. Open the System Setup folder.
3. Open the System object.
4. From the selection windows provided, select a new screen resolution and screen refresh rate.

Note that refresh rates other than 60 Hz are only valid when the display is switched to CRT Only display mode.

5. Close the System-Settings notebook.
6. Perform a shutdown and restart for the changes to take effect.

Installation Notes

1. During the installation of this driver, DISPLAY.LOG and DSPINSTL.LOG files are created in the \OS2\INSTALL directory. These files identify the OS/2 system files that were updated, and indicate whether the installation was successful. The DISPLAY.LOG file also contains a string that identifies the version of driver that was installed. This information may be important when reporting an installation problem.
2. During installation, DSPINSTL will invoke the SVGA Configuration program SVGA.EXE to determine the hardware configuration, and create the file \OS2\INSTALL\SVGADATA.PMI. If this file is not created, the adapter will not be supported. When this step is done, the display will be blanked out. You may see a series of flashes on the display and/or what appears to be a “corrupted” display. This is normal, as the configuration process is performing Video BIOS mode sets to determine which screen resolutions BIOS supports. This configuration information is then used to provide the System-Settings Resolution and Refresh selections.

APPENDIX **A**

Programming the Watchdog Timer

The PCA-6154/6154L is equipped with a watchdog timer that resets the CPU or generates an interrupt if processing comes to a standstill for any reason. This feature ensures system reliability in industrial standalone or unmanned environments.

A.1 Programming the Watchdog Timer

To program the watchdog timer, you must write a program which writes I/O port address 443 (hex). The output data is a value of time interval. The value range is from 01 (hex) to 3F (hex), and the related time interval is 1 sec. to 63 sec.

Data	Time Interval
01	1 sec.
02	2 sec.
03	3 sec.
04	4 sec.
•	•
•	•
•	•
3F	63 sec.

After data entry, your program must refresh the watchdog timer by rewriting the I/O port 443 (hex) while simultaneously setting it. When you want to disable the watchdog timer, your program should read I/O port 443 (hex).

The following example shows how you might program the watchdog timer in BASIC:

```
10      REM  Watchdog timer example program
20      OUT &H443, data REM  Start and restart the watchdog
30      GOSUB 1000 REM  Your application task #1,
40      OUT &H443, data REM  Reset the timer
50      GOSUB 2000 REM  Your application task #2,
60      OUT &H443, data REM  Reset the timer
70      X=INP (&H443) REM, Disable the watchdog timer
80      END

1000    REM  Subroutine #1, your application task
.      .
.      .
.      .
1070    RETURN
2000    REM  Subroutine #2, your application task
.      .
.      .
.      .
2090    RETURN
```

APPENDIX **B**

Installing PC/104 Modules

This appendix gives instructions for installing PC/104 modules.

B.1 Installing PC/104 modules

The PCA-6154/6154L's PC/104 connectors give you the flexibility to attach PC/104 modules.

Installing these modules on the PCA-6154/6154L is quick and simple. The following steps show how to mount the PC/104 modules:

1. Remove the PCA-6154/6154L from your system paying particular attention to the safety instructions already mentioned above.
2. Make any jumper or link changes required to the CPU card now. Once the PC/104 module is mounted you may have difficulty in accessing these.
3. Normal PC/104 modules have male connectors and mount directly onto the main card. (Refer to the diagram on the following page.)
4. Mount the PC/104 module onto the CPU card by pressing the module firmly but carefully onto the mounting connectors.
5. Secure the PC/104 module onto the CPU card using the four mounting spacers and screws.

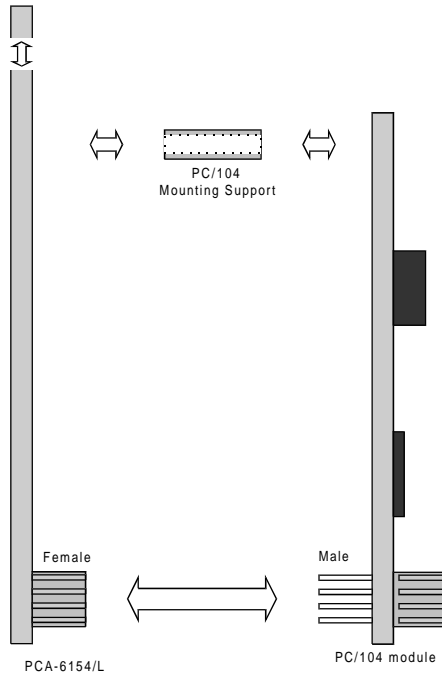

Figure B-1: PC/104 module mounting diagram

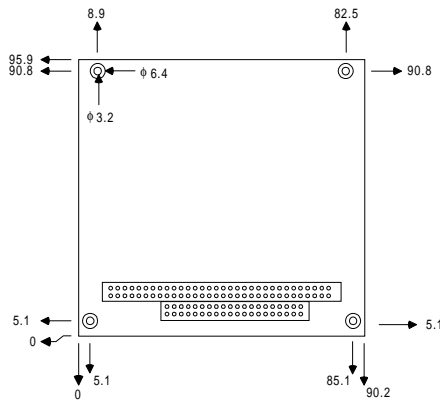

Figure B-2: PC/104 module dimensions (mm) (± 0.1)

Table B-1: PCA-6154/6154L PC/104 connectors (CN12, CN13)

Pin Number	Signal (CN12)		Signal (CN13)	
	Row A	Row B	Row C	Row D
0	—	—	0 V	0 V
1	IOCHCHK*	0 V	SBHE*	MEMCS16*
2	SD7	RESETDRV	LA23	IOCS16*
3	SD6	+5 V	LA22	IRQ10
4	SD5	IRQ9	LA21	IRQ11
5	SD4	-5 V	LA20	IRQ12
6	SD3	DRQ2	LA19	IRQ15
7	SD2	-12 V	LA18	IRQ14
8	SD1	ENDXFR*	LA17	DACK0*
9	SD0	+12 V	MEMR*	DRQ0
10	IOCHRDY	N/C	MEMW*	DACK5*
11	AEN	SMEMW*	SD8	DRQ5
12	SA19	SMEMR*	SD9	DACK6*
13	SA18	IOW*	SD10	DRQ6
14	SA17	IOR*	SD11	DACK7*
15	SA16	DACK3*	SD12	DRQ7
16	SA15	DRQ3	SD13	+5 V
17	SA14	DACK1*	SD14	MASTER*
18	SA13	DRQ1	SD15	0 V
19	SA12	REFRESH*	KEY	0 V
20	SA11	SYSCLK	—	—
21	SA10	IRQ7	—	—
22	SA9	IRQ6	—	—
23	SA8	IRQ5	—	—
24	SA7	IRQ4	—	—
25	SA6	IRQ3	—	—
26	SA5	DACK2*	—	—
27	SA4	TC	—	—
28	SA3	BALE	—	—
29	SA2	+5 V	—	—
30	SA1	OSC	—	—
31	SA0	0 V	—	—
32	0 V	0 V	—	—

*active low

Pin Assignments

This appendix contains information of a detailed or specialized nature. It includes:

- CRT display connector
- RS-232/422/485 serial port connector
- Keyboard and mouse connector
- External keyboard connector
- Main power connector
- IDE connector
- RS-232 serial port connector
- Ethernet RJ-45 connector
- Floppy connector
- Parallel connector
- IR connector
- HDD LED connector

C.1 CRT Display Connector (CN7)

Table C-1: PCA-6154/6154L CRT display connector

Pin	Signal	Pin	Signal
1	RED	9	N/C
2	GREEN	10	GND
3	BLUE	11	N/C
4	N/C	12	N/C
5	GND	13	H-SYNC
6	GND	14	V-SYNC
7	GND	15	N/C
8	GND		

C.2 COM1 RS-232 Serial Port (CN11)

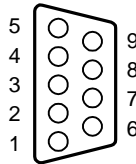

Table C-2: PCA-6154/6154L COM1 RS-232 serial port

Pin	Signal
1	DCD
2	RXD
3	TXD
4	DTR
5	GND
6	DSR
7	RTS
8	CTS
9	RI

C.3 COM2 RS-232/422/485 Serial Port (CN10)

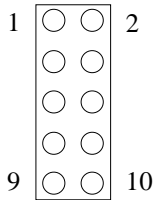

Table C-3: PCA-6154/6154L COM2 RS-232/422/485 series port

Pin	RS-232 port	RS-422 port	RS-485 port
1	DCD	TXD-	DATA-
2	DSR	N/C	N/C
3	RxD	TXD+	DATA+
4	RTS	N/C	N/C
5	TxD	RXD+	N/C
6	CTS	N/C	N/C
7	DTR	RXD-	N/C
8	RI	N/C	N/C
9	GND	GND	GND
10	N/C	N/C	N/C

C.4 Keyboard and Mouse Connector (CN15)

Table C-4: PCA-6154/6154L keyboard and mouse connector

Pin	Signal
1	KB DATA
2	MS DATA
3	GND
4	V _{cc}
5	KB CLOCK
6	MS CLOCK

C.5 External Keyboard Connector (CN14)

Table C-5: PCA-6154/6154L external keyboard connector

Pin	Signal
1	CLK
2	DATA
3	NC
4	GND
5	V _{cc}

C.6 Main Power Connector (CN6)

Table C-6: PCA-6154/6154L main power connector

Pin	Signal
1	PGD (power good)
2	+5 V
3	+12 V
4	-12 V
5	GND
6	GND

C.7 IDE Hard Drive Connector (CN1)

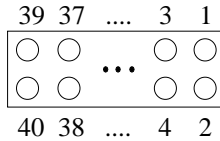

Table C-7: PCA-6154/6154L IDE hard drive connector

Pin	Signal	Pin	Signal
1	IDE RESET*	2	GND
3	DATA 7	4	DATA 8
5	DATA 6	6	DATA 9
7	DATA 5	8	DATA 10
9	DATA 4	10	DATA 11
11	DATA 3	12	DATA 12
13	DATA 2	14	DATA 13
15	DATA 1	16	DATA 14
17	DATA 0	18	DATA 15
19	SIGNAL GND	20	N/C
21	N/C	22	GND
23	IO WRITE	24	GND
25	IO READ	26	GND
27	IO CHANNEL READY	28	N/C
29	HDACKO*	30	GND
31	IRQ14	32	IOCS16
33	ADDR 1	34	N/C
35	ADDR 0	36	ADDR 2
37	HARD DISK SELECT 0*	38	HARD DISK SELECT 1*
39	IDE ACTIVE*	40	GND

* Low active

C.8 USB Connector (CN9)

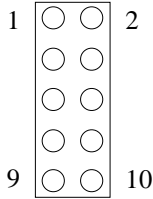

Table C-8: USB1/USB2 connector

Pin	USB1 Signal	Pin	USB2 Signal
1	+5 V	2	+5 V
3	UV-	4	UV-
5	UV+	6	UV+
7	GND	8	GND
9	Chassis GND	10	N/C

C.9 CPU Fan Power Connector (CN4)

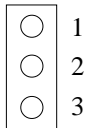

Table C-9: PCA-6154/6154L CPU fan power connector

Pin	Signal
1	+5 V
2	GND
3	+12 V

C.10 Front Panel Connector (CN16)

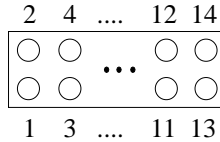

Table C-10: PCA-6154/6154L front panel connector

Pin	Signal	Pin	Signal
1	V _{cc}	2	POWER LED
3	N/C	4	N/C
5	BUZZER	6	GND
7	SPEAKER	8	KB_LCK
9	N/C	10	GND
11	WATCHDOG OUT (HWD RESET)	12	GND
13	N/C	14	GND

C.11 Ethernet RJ-45 Connector (CN8)

Table C-11: PCA-6154/6154L Ethernet RJ-45 connector

Pin	Signal	Pin	Signal
1	TD+	2	TD-
3	RD+	4	N/C
5	N/C	6	RD-
7	N/C	8	N/C

C.12 Floppy Drive Connector (CN2)

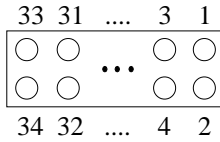

Table C-12: PCA-6154/6154L floppy drive connector

Pin	Signal	Pin	Signal
1	GND	2	DENSITY SELECT*
3	GND	4	N/C
5	GND	6	N/C
7	GND	8	INDEX*
9	GND	10	MOTOR 0*
11	GND	12	DRIVE SELECT 1*
13	GND	14	DRIVE SELECT 0*
15	GND	16	MOTOR 1*
17	GND	18	DIRECTION*
19	GND	20	STEP*
21	GND	22	WRITE DATA*
23	GND	24	WRITE GATE*
25	GND	26	TRACK 0*
27	GND	28	WRITE PROTECT*
29	GND	30	READ DATA*
31	GND	32	HEAD SELECT*
33	GND	34	DISK CHANGE*

* Low active

C.13 Parallel Port Connector (CN3)

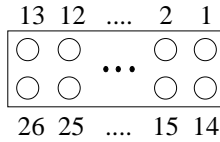

Table C-13: PCA-6154/6154L parallel port connector

Pin	Signal
1	\STROBE
2	\AUTOFD
3	D0
4	ERR
5	D1
6	\INIT
7	D2
8	\SLCTINI
9	D3
10	GND
11	D4
12	GND
13	D5
14	GND
15	D6
16	GND
17	D7
18	GND
19	\ACK
20	GND
21	BUSY
22	GND
23	PE
24	GND
25	SLCT
26	N/C

C.14 IR Connector (CN5)

Table C-14: PCA-6154/6154L IR connector

Pin	Signal
1	+5 V
2	N/C
3	IR_RX
4	GND
5	IR_TX

C.15 HDD LED Connector (CN17)

Table C-15: PCA-6154/6154L HDD LED connector

Pin	Signal
1	V _{cc}
2	LED

C.16 System I/O Ports

Table C-16: System I/O ports

Addr. range (Hex)	Device
000-01F	DMA controller
020-021	Interrupt controller 1, master
022-023	Chipset address
040-05F	8254 timer
060-06F	8042 (keyboard controller)
070-07F	Real-time clock, non-maskable interrupt (NMI) mask
080-09F	DMA page register,
0A0-0BF	Interrupt controller 2
0C0-0DF	DMA controller
0F0	Clear math co-processor
0F1	Reset math co-processor
0F8-0FF	Math co-processor
1F0-1F8	Fixed disk
200-207	Game I/O
278-27F	Parallel printer port 2 (LPT 3)
2F8-2FF	Serial port 2
300-31F	Prototype card
360-36F	Reserved
378-37F	Parallel printer port 1 (LPT 2)
380-38F	SDLC, bisynchronous 2
3A0-3AF	Bisynchronous 1
3B0-3BF	Monochrome display and printer adapter (LPT1)
3C0-3CF	Reserved
3D0-3DF	Color/graphics monitor adapter
3F0-3F7	Diskette controller
3F8-3FF	Serial port 1

* PNP audio I/O map range from 220 ~ 250H (16 bytes)
 MPU-401 select from 300 ~ 330H (2 bytes)

C.17 DMA Channel Assignments

Table C-17: DMA channel assignments

Channel	Function
0	Available
1	Available
2	Floppy disk (8-bit transfer)
3	Available
4	Cascade for DMA controller 1
5	Available
6	Available
7	Available

* Audio DMA select 0, 1 or 3

C.18 Interrupt Assignments

Table C-18: Interrupt assignments

Interrupt#	Interrupt source
IRQ 0	Interval timer
IRQ 1	Keyboard
IRQ 2	Interrupt from controller 2 (cascade)
IRQ 8	Real-time clock
IRQ 9	Cascaded to INT 0A (IRQ 2)
IRQ 10	Available
IRQ 11	Available
IRQ 12	PS/2 mouse (non-releasable)
IRQ 13	INT from co-processor
IRQ 14	Fixed disk controller
IRQ 15	Not available
IRQ 3	Serial communication port 2
IRQ 4	Serial communication port 1
IRQ 5	Parallel port 2
IRQ 6	Diskette controller (FDC)
IRQ 7	Parallel port 1 (print port)

* PNP audio IRQ select: 5, 7, 9, 10, 11 or 12

* Ethernet function is auto-sensing

C.19 1st MB Memory Map

Table C-19: 1st MB memory map

Addr. range (Hex)	Device
F000h - FFFFh	System ROM
C800h - EFFFh	Unused
C000h - C7FFh	Expansion ROM
B800h - BFFFh	CGA/EGA/VGA text
B000h - B7FFh	Unused
A000h - AFFFh	EGA/VGA graphics
0000h - 9FFFh	Base memory

APPENDIX **D**

DOC[®] 2000 Installation Guide

This appendix contains information on the DiskOnChip[®] 2000 quick installation guide. It includes:

- DiskOnChip[®] 2000 installation instructions
- Additional information and assistance

DiskOnChip® 2000 Quick Installation Guide

DiskOnChip® 2000 installation instructions

1. Make sure the target platform is powered OFF.
2. Plug the DiskOnChip® 2000 device into its socket. Verify the direction is correct (pin 1 of the DiskOnChip® 2000 is aligned with pin 1 of the socket).
3. Power up the system.
4. During power up you may observe the messages displayed by the DiskOnChip® 2000 when its drivers are automatically loaded into the system's memory.
5. At this stage the DiskOnChip® 2000 can be accessed as any disk in the system.
6. If the DiskOnChip® 2000 is the only disk in the system, it will appear as the first disk (drive C: in DOS).
7. If there are more disks besides the DiskOnChip 2000, the DiskOnChip® 2000 will appear by default as the last drive, unless it was programmed as the first drive. (Please refer to the DiskOnChip® 2000 utilities user manual.)
8. If you want the DiskOnChip® 2000 to be bootable:
 - a. Copy the operating system files into the DiskOnChip® by using the standard DOS command (for example: sys d:).
 - b. The DiskOnChip® should be the only disk in the systems or would be configured as the first disk in the system (c:) using the DUPLICATE utility.

```
DUPLICATE D /S: DOC104.EXB /FIRST (set as c:)
DUPLICATE C /S: DOC104.EXB (set as d:)
```

Additional information and assistance

1. Visit M-Systems' Web site at www.m-sys.com where you can find Utilities Manual, Data Sheet and Application Notes. In addition, you can find the latest DiskOnChip® 2000 S/W Utilities.
2. Contact your dealer for technical support if you need additional assistance, and have the following information ready:
 - Product name and serial number.
 - Description of your computer hardware (manufacturer, model, attached devices, etc.)
 - Description of your software (operating system, version, application software, etc.)
 - A complete description of the problem.
 - The exact wording of any error messages.

